

4Z Input/2 Output Expansion SnapCard™

Document Number: 466-1367 Rev. B
September 1998

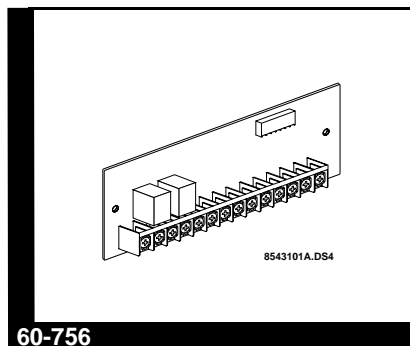

INSTALLATION INSTRUCTIONS

Product Summary

The Four Zone Input/Two Output Expansion SnapCard™ combines the capabilities of the Eight Zone Input and Four Output Expansion SnapCards. It allows for Concord™ panel, Advent™ panel, and Superbus™ 80 Zone Input/16 Output Module expansion.

The card includes the following:

- One 12V two-wire smoke detector loop that provides power (100mA) to Style B (Class B) smoke detectors.
- Three supervised UL Fire rated hardwire loops (2k ohm EOL resistors required) that can be used for any hardwire device including:
4-wire smoke detectors, fire pulls, water flow detector switches, gate valve switches, control valve supervisory switches, butterfly valve switches, rate-of-rise detectors, carbon monoxide gas detectors, assorted other gas detectors and standard burglar devices.
- False alarm prevention.
When the panel receives an alarm from a smoke detector, the panel briefly interrupts power to the smoke loop. Smoke detectors reset and recheck the alarm.
- Two "Form C" contact relays. The relays are controlled by a touchpad or a combination of states and events in the system.

On Advent™ panels, and Superbus™ 80 Zone Input/16 Output Modules, this card may be installed into the primary or secondary expansion slot and in combination with other cards.

Devices may be programmed to perform in various ways. You can use the touchpad to turn on lights and open drapes or a garage door. You can program the system to turn on a closed-circuit-TV (CCTV) camera during a burglary alarm, turn exit lighting on during a fire alarm or activate backup cellular phones or long-range radios if primary communications are inoperable.

Installation Guidelines

- Install a 2k ohm EOL resistor at the end device on each supervised two-wire hardwire loop.
- Install a power supervision module at the end device on four-wire smoke loops.
- Plug the expansion card into the Concord™ panel expansion slot or either the primary or secondary expansion slot of the Advent™ panel or Superbus™ 80 Zone Input/16 Output Module.
- Use 4-conductor, 22-gauge or larger stranded wire from the terminals to the devices.

Tools Needed (optional)

- Screwdriver
- Four-conductor, 22-gauge or larger stranded hookup wire
- Thread rolling mounting screws (included)
- 2K ohm end-of-line (EOL) resistors

Installation

Use the following instructions to install the card, wire input devices, and program the panel.

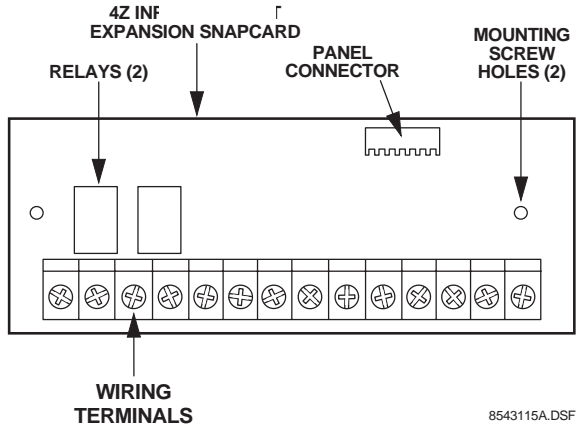

Figure 1. Card Components

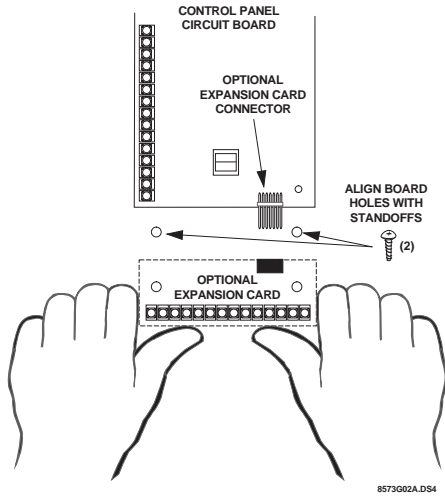

Figure 2. Installing the Card in Concord Panel

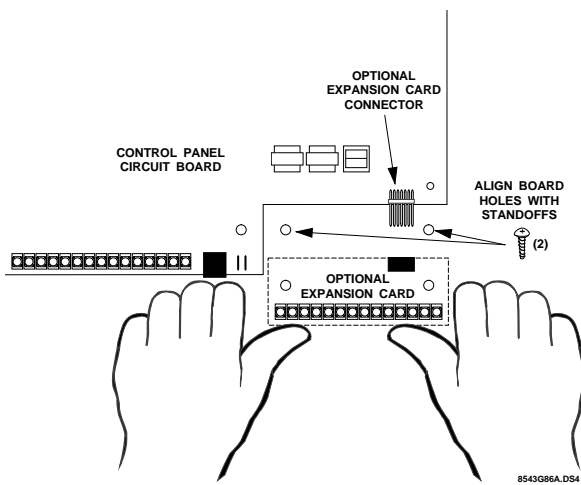

Figure 3. Installing the Card in Advent Panel and SuperBus 80Z Input/16 Output Modules

CAUTION: To prevent damaging the panel or card, always remove panel AC power and disconnect backup battery before installation.

1. Disconnect panel power and backup battery.



WARNING: You must be free of all static electricity when handling electronic components. Touch a bare metal surface before touching the circuit board.

2. Align the card holes with the standoffs and connector pins as shown in figure 2 or 3.
3. Press firmly to secure the board to the connector
4. Secure the card with the two thread rolling metal screws.

Wiring

The following table and figure shows you how to wire the card. Terminals are numbered left to right.

Note: Terminal 11 (SMK+) can also power 4-wire smoke detectors.

Table 1. Card Wiring Terminal Descriptions

Terminal Number	Description	Use
1	Relay 1 NC	Normally closed (N/C) (opens on activation) output 1 dry relay contact connection.
2	Relay 1 COM	Common (C) side of output 1 dry relay N/C and N/O contacts (terminals 1 and 3). Contacts rated 5.0 A @30 VDC maximum.
3	Relay 1 NO	Normally open (N/O) (closes on activation) output 1 dry relay contact connection.
4	Relay 2 NC	Normally closed (N/C) (opens on activation) output 2 dry relay contact connection.
5	Relay 2 COM	Common (C) side of output 2 dry relay N/C and N/O contacts (terminals 2 and 6). Contacts rated 5.0 A @30 VDC maximum.
6	Relay 2 NO	Normally open (N/O) (closes on activation) output 2 dry relay contact connection.
7	ZN1	Hardwire Input zone 1
8	ZCOM	Common for hardwire input zones 1, 2, and 3.

Table 1. Card Wiring Terminal Descriptions (Continued)

Terminal Number	Description	Use
9	ZN2	Hardwire Input zone 2
10	ZN3	Hardwire Input zone 3
11	SMK+	Smoke sensor power supply. Switched 12 VDC @ 100 mA maximum. Positive (+) side of 2-wire, 12 VDC smoke loop.
12	SMK-	Negative (-) side of 2-wire, 12 VDC smoke loop.
13	GND	Common ground for 4-wire smoke sensors, and rate-of-rise heat sensors
14	12VDC	Auxiliary DC power supply. 12 VDC @ 500 mA maximum.

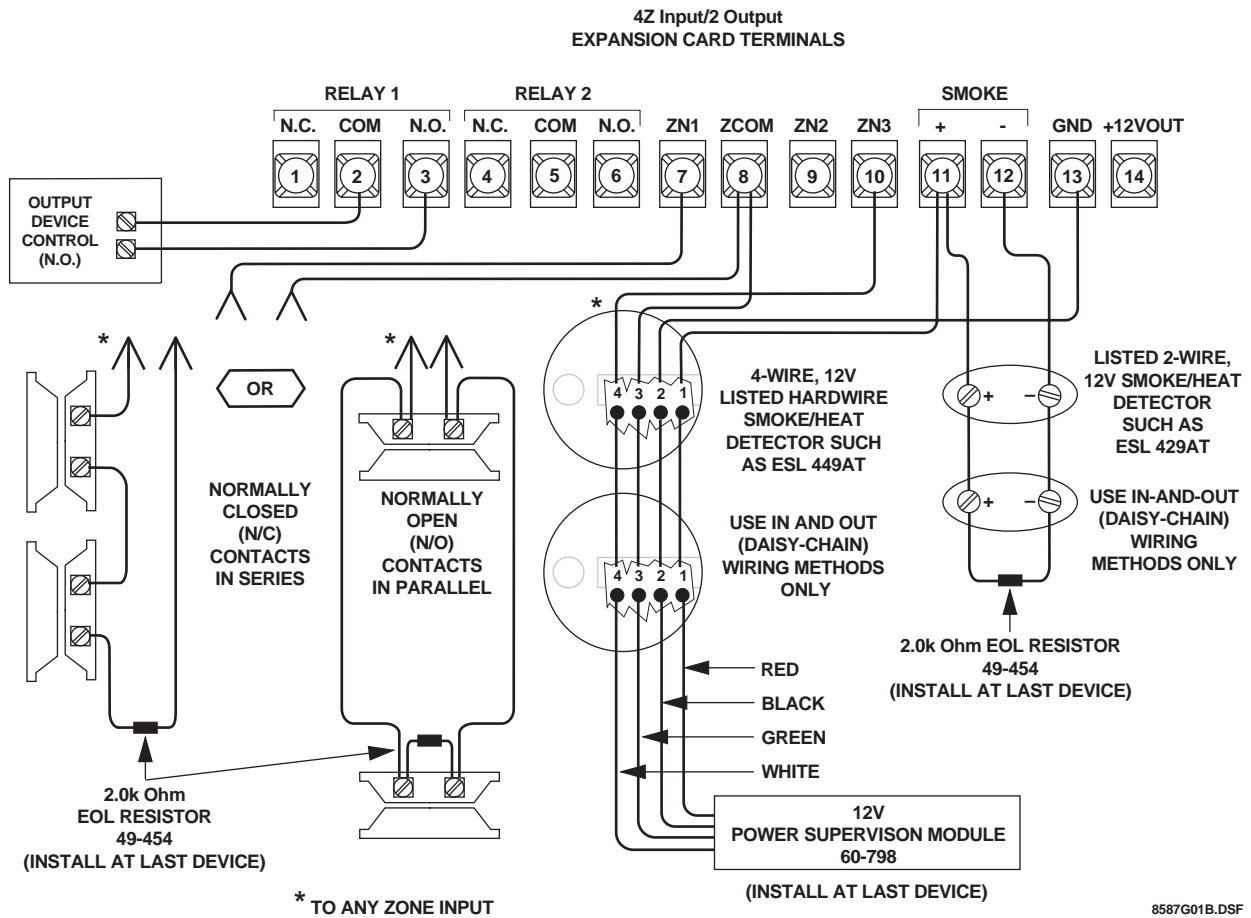

Figure 4. Typical 4Z Input/2 Output SnapCard Wiring

To wire the card:

1. Disconnect panel power and backup battery.
2. Wire the smoke detectors or other devices. Table 2 describes how to wire various devices. Use terminals 11 and 12 for the two-wire 12V smoke detector loop. (You can connect up to 20 two-wire smoke detectors on this loop.)
3. Use EOL resistors as shown on any hardware loops.
4. Reconnect the backup battery and panel AC power.

Programming

Input and output zones must be programmed to communicate with the panel and to function as desired. For zone programming information, refer to the panel *Installation Instructions*.

Testing

Once installed, the card becomes an integral part of the panel. We recommend that you test all input and output zones after all programming is completed and whenever a sensor or output related problem occurs. Refer to the panel *Installation Instructions* and *User's Manual* for sensor/zone testing information.

Note: While the sensor test is a valuable installation and service tool, it only tests sensor operation for the current conditions. You should perform a sensor test after any change in environment, equipment, or programming.

Troubleshooting (all panels)

The following instructions help you diagnose and fix card hardware input and output problems.

Troubleshooting Hardware Inputs

No inputs detected.

1. Check input device wiring and connections.
2. Check panel input programming.

One input is never detected.

1. Check input device wiring and connections.
2. Check panel input programming.

Wrong input is detected.

1. Check panel input programming.
2. Check input device wiring and connections.

Sensor Trouble is indicated.

1. Check that the 2.0K ohm end-of-line resistor is correctly installed in the zone loop circuit.
2. Check normally open (N/O) input circuit for a break in the wires.
3. Check normally closed (N/C) input circuit for a short in the wires.
4. Check input circuit for wires shorted to ground.
5. Check that ZCOM (terminal 8) is used for input zone common and not GND (terminal 13).

Troubleshooting Hardware Outputs

No outputs activate:

1. Check panel/card programming.
2. Check output wiring and connections.
3. Check panel/card power supplies.
4. If used, check the optional external supply powering the output devices.

One output never activates:

1. Check panel/card programming for that output.
2. Check output wiring and connections.
3. Check that the output programmed trigger event actually occurs.
4. An output relay may have failed or been overloaded. Reprogram to use a different (unused) output or replace the card.

Wrong output activates:

1. Check panel output programming.
2. Check output device wiring and connections.

Specifications

Compatibility: Concord™ and Custom Versions panels, Advent™ and Custom Versions panels, Super-Bus™ 80 Zone Input/16 Output Modules.

Power Source: 12 VDC @ 185 ma maximum (from panel and panel backup battery).

Storage Temperature: -30° to 120° F (-34° to 49° C)

Operating Temperature: 40° to 100° F (4° to 38° C)

Maximum Humidity: 70% relative humidity, noncondensing.

Inputs: Three supervised UL Fire rated hardwire zones.

One 12V two-wire smoke detector loop that provides power (100mA) to Style B (Class B) smoke detectors. Up to twenty devices.

Outputs: Two “Form C” contact relays. Contacts rated 5.0 A at 30 VDC maximum (each contact).

Dimensions: 2.0” x 5.25” x 0.75” (H x W x D)

Installation: In panel mounting.

Notices

This device complies with part 15 of the FCC rules. Operation is subject to the following two conditions:

1. This device may not cause harmful interference.
2. This device must accept any interference received, including interference that may cause undesired operation.

Changes or modifications not expressly approved by Interactive Technologies, Inc. can void the users' authority to operate the equipment.



WIRELESS

Security

Automation

Access Control

INTERACTIVE TECHNOLOGIES, INC.

2266 SECOND STREET NORTH
NORTH SAINT PAUL, MN 55109

T: 651/777-2690

F: 651/779-4890

ITI is a registered trademark of Interactive Technologies, Inc. SnapCard, SuperBus, Concord and Advent are trademarks of Interactive Technologies, Inc.

