



# GSM Cellular Module for Simon XT Installation Instructions

## Introduction

These are the Installation Instructions for the Alarm.com *GSM Cellular Module for Simon XT*. The GSM Cellular Module enables wireless reporting of all alarms and other system events from the GE Simon XT control panel using an all-digital, GSM/GPRS wireless (cellular) network. The module can be used as the primary communication path for all alarm signaling, or as a backup to a telephone line connection to the central monitoring station. The wireless alarm signaling and routing service is operated by Alarm.com. The module interfaces with the Simon XT panel board, fits into a special compartment inside the panel, and is powered by the control panel and panel battery.

## Account Creation

Before installing an Alarm.com GSM Module in a Simon XT system, a new customer account needs to be created with Alarm.com. We recommend creating the account at least 24 hours in advance of installation to ensure that the radio is activated prior to installation.

To activate an account go to [www.alarm.com/dealer](http://www.alarm.com/dealer) and login. Click on the "Customers" tab at the top left of the page. Then click on the "Create Customer" subtab on the line below. You will need the following customer information to create the account:

- Customer Name
- Customer Address
- Customer Phone Number
- Customer E-mail
- Preferred login name for the customer
- Alarm.com Radio Serial Number

At the end of the account creation process you will be able to print a Welcome Letter for the customer that has their login information and temporary password for the Alarm.com website.

## Installation

Installation consists of removing the plastic cover over the antenna aperture, inserting the GSM module inside the control panel, and attaching the antenna.

Follow these guidelines during installation:

- Do not exceed the panel total output power when using panel power for the GSM module, hardwired sensors, and /or sirens. Refer to the specific panel installation instructions for details.
- Simon XT panels allow a maximum of one Alarm.com GSM module.
- The GSM module draws a maximum of 30 mA average during normal operation. In PowerSave

mode, during or immediately following an AC power failure, the module will draw only 10 mA on average.

- Avoid mounting the panel in areas with excessive metal or electrical wiring, such as furnace or utility rooms.
- Leave 12 to 18 in. of open space around the module antenna.
- Do not install the control panel and module in a basement or other below-ground location. Doing so will negatively impact GSM signal strength.

## Tools and supplies needed

You will need the following tools and supplies:

- Small flat-head and Phillips screwdrivers;
- Screws (included); and
- Antenna (included).

## Inserting the Module and Installing the Antenna

Before installing the module, disconnect the battery and AC power from the panel.

1. Open the panel. This can be done by pressing the two triangle-shaped tabs (*Figure 1*) on the top of the panel.

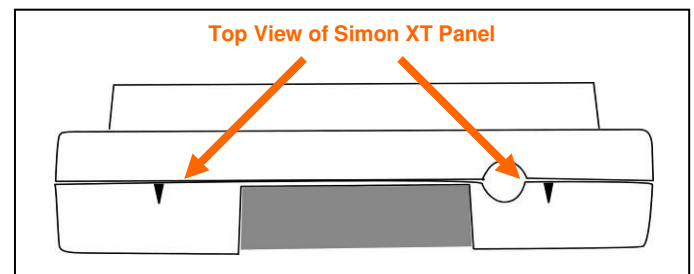

Figure 1

2. The GSM module compartment can be found behind the front panel that swings down, to the left of the battery compartment, as seen in *Figure 2*.

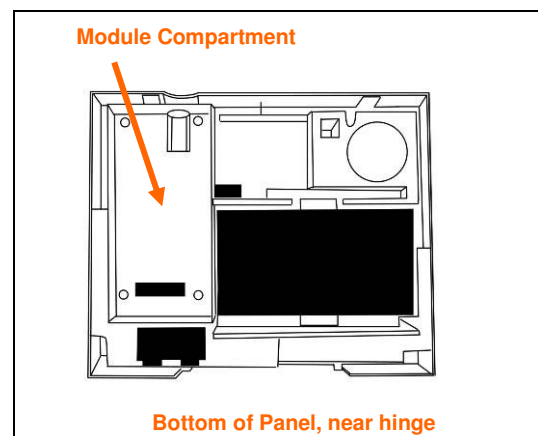

Figure 2

3. Remove the plastic covering the antenna aperture by cutting the plastic tabs near the module compartment. In *Figure 3* the plastic that should be removed was shaded red.

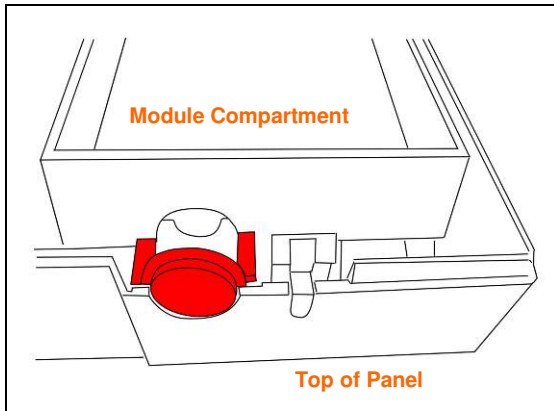

Figure 3

4. Insert the module by angling it down and placing the antenna connector in the round opening. **IMPORTANT:** Make sure to angle the top of the module downward when inserting the antenna connector into the opening, so the module is below the two small, plastic corner tabs in the top of the module compartment (seen in *Figure 4*).

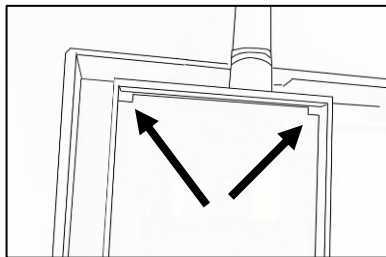

Figure 4

*Make sure the module is BELOW the two corner tabs.*

Once the module is seated evenly, carefully push the bottom of the module into the 8-pin connector beneath it.

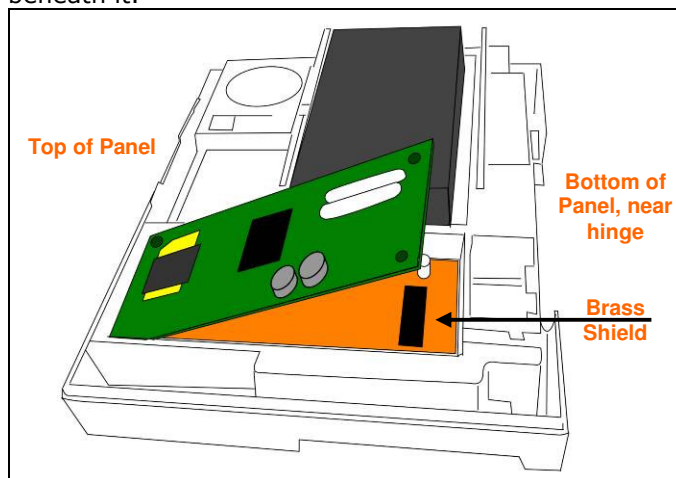

Figure 5

5. Screw the antenna onto the module. Make sure the antenna is screwed in completely (a little over 2 turns), but do not force it. The module must be seated correctly beneath the two small, plastic corner tabs (see *Figure 4*) for the antenna to thread freely through the round opening. If the module is above either corner tab, the module and the antenna will not fit correctly.

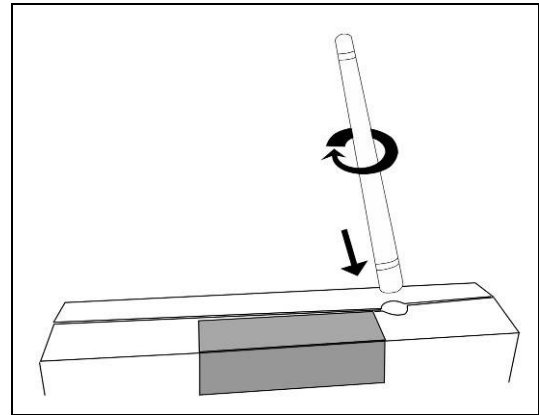

Figure 6

### Brass Shield

To reduce the possibility that the GSM module will affect the panel's RF sensor range, you can install a brass shield beneath the module. A brass shield is included in some versions of the GSM module kit. *Figure 5* shows the location of the brass shield underneath the module.

### Power up

When a GSM module is connected to the control panel, the panel LCD display will say "GSM Module OK" for 15 seconds. If it does not display that message, check the 4 LEDs at the bottom of the radio (see LED section below). If the LEDs do not light up at all, perform a full power cycle by following these steps:

1. Disconnect the battery leads and unplug the system from AC power.
2. Verify that the module is inserted securely and that the antenna is screwed in completely.
3. Connect battery leads to the battery. Observe polarity, red to + and black to -.
4. Place the battery inside the battery compartment making sure to keep the wires outside of the tab holding them in place.
5. Plug the panel power transformer into the AC outlet.

It is important to plug the battery in before plugging in the AC, otherwise the panel will issue a "System Low Battery" message regardless of the battery voltage level.

### GSM Phone Test (Module Registration)

To make the module connect to Alarm.com and the GSM network the first time, you can do a "GSM phone test" or initiate a panic/alarm. To do a GSM phone test, perform the following steps:

1. Scroll Down through the control panel menu until it displays "System Tests" and Press Enter (↵).
2. Enter the installer code (default 4-3-2-1), then Press Enter (↵).
3. Scroll down until the panel displays "Comm Test" and Press Enter (↵).
4. The panel will let you know when the GSM Phone Test has succeeded by displaying "GSM Test signal sent OK" on the panel LCD display.

The Panel will display the following information for the GSM Phone Test:

"GSM Comm Test in progress" when the test starts.

"GSM Comm Test not available" if GSM Phone tests are disabled (they are enabled by default).

"GSM Comm Test: no more trials" if the allocation of 10 tests\*\* has been used up.

"GSM test signal sent OK Press Status to end" when Alarm.com has received and acknowledged the signal. This does not guarantee that the signal went through to a central station; it confirms that the Alarm.com Operations Center received the signal. The central station should be contacted directly to verify that the signal was received on the correct account and that the Central Station routing settings have been set up correctly. The signal may not go through to the central station if (a) the Central Station Account settings were entered incorrectly on the Alarm.com Dealer website or (b) if Alarm.com was unable to send the signal successfully to the Central Station receivers. In these cases the panel will show a "Fail to Communicate" message.

**\*\*Note:** At power up, the module starts with an allocation of 10 GSM phone tests. One test allocation will be added every 24h after that to replenish the 10 tests allocation. If more GSM phone tests are required, perform a full power cycle.

### Control Panel Settings that Change Automatically with GSM module

Some panel settings are changed automatically when the GSM module is connected to the control panel. These settings should not be altered by the installer. They are:

**Sensor/Zone 40.** Upon initial module power up, the panel recognizes and learns the GSM module as sensor/zone 40 and assigns "GSM Module" as the sensor/zone name. Any device previously residing in panel memory as sensor/zone 40 is automatically

deleted and must be learned into panel memory using any available sensor/zone number between 01 and 39.

**Clock.** The GSM module sets the panel clock when it connects to Alarm.com and then updates it every 18 hours. It is important to select the correct panel time zone on the Alarm.com website, or the panel time will not be accurate. If a system is powered up before the customer account has been created, the time zone will default to Eastern Time.

### Troubleshooting: LEDs

Status LEDs indicate network and module status. Figure 7 shows the location of the LEDs visible through a slit at the back of the panel.

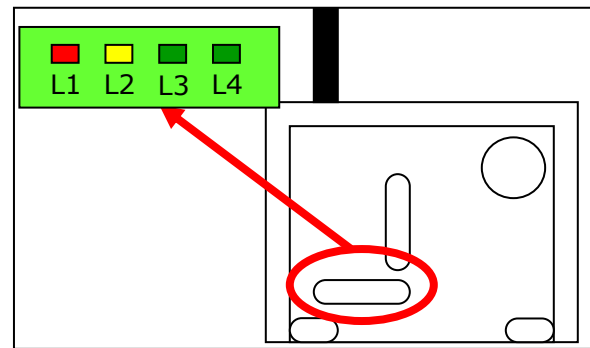

Figure 7

Table 2 describes the LED functions.

LED	Function
L1	Error LED. Will flash 1 to 8 times in an 8-second interval to indicate specific error conditions such as network error, panel communication error, or GSM radio error.
L2	Panel Communication. Flashes every time the module communicates with the panel.
L3	GSM Communication. Flashes every time the GSM signal level is checked or for every packet sent or received to and from Alarm.com.
L4	GSM Signal Level. Flashes 0 to 5 times to indicate signal strength, or toggles on/off when communicating with Alarm.com servers.

See [LED Details](#) for more detailed LED information.

## LED Details

### LED 1 (red)

LED 1 flashes when there is an error. The number of flashes is the error number. If there are two or more errors at the same time, the errors will be flashed one after the other. The LED will stay off for at least four seconds between errors.

Errors Flashed on LED 1 (RED)	
Number of Flashes	Error and Solution
1	Module cannot communicate with the panel. Perform a power cycle on the panel. See <i>Power Up</i> . If it still doesn't work, lift the module out of the panel and re-insert it. If this doesn't fix the problem, try a different module. Finally, if that does not fix the problem try a different panel.
2	The SIM card is missing. The SIM card holder can be found on the module. Verify that the SIM card holder is closed securely and that there is a SIM card in the holder.
3	The module is trying to register on the GSM network. It's normal if it doesn't last more than 30 seconds. If it persists for more than a few minutes, the module is having problems registering with the GSM network. Check LED 4 for signal level. If signal level is too low, change the panel's location or use a remote antenna option. If the signal is good, the module may be roaming on a GSM network that doesn't partner with our GSM providers, or the SIM card was not activated yet because the Alarm.com account was not created correctly. If the module had been communicating in the past, there may be new RF interference from some other device or building.
4	The module is registered on the GSM network but cannot connect with Alarm.com. Contact Alarm.com Technical Support.
5	Radio portion of the module is not working correctly. If this persists for more than a few minutes, the module may need to be replaced. This error is extremely rare so verify that the module is flashing 5 times.
6	This is an error only if it persists for more than a minute. Otherwise, it's just an indication that the module is fixing an unusual condition regarding communication with the GSM network.
7	The module being used has been programmed for a regular Simon panel (not XT). Please label the module appropriately and swap it with a different, Simon XT module.
8	If it persists, the account may have been set up incorrectly. Contact Alarm.com Technical Support. You will be asked to check the serial number of the module.

### LED 2 (yellow)

LED 2 flashes with every communication between the module and the panel. Normal pattern calls for a

series of quick flashes every two seconds in Idle Mode or four seconds in PowerSave Mode.

### LED 3 (green)

LED 3 flashes with every communication between the module and its radio unit in Idle mode, and with every communication with Alarm.com in Connected Mode. In PowerSave mode, this LED flashes in unison with LED 2.

### LED 4 (green)

LED 4 indicates the GSM signal level as a number of flashes (0 to 5 bars). The number of bars may not correspond to the bars shown on your cell phone. A level of 5 bars is obtained only in the strongest signal conditions.

Signal level is updated every ten seconds if it fluctuates, or every 30 seconds if it is fairly stable. If LED 4 is not flashing it indicates one of the following states:

- The module is in power save mode;
- The module just powered up;
- There is no GSM coverage in the area. Alarm.com recommends a signal level of 2 or higher for proper operation of the module.

In connected mode, the LED toggles on and off.

### LED Patterns for the Various Module States (modes)

There are three module states, or modes, as described below:

**Idle Mode.** AC power is OK and the module is not currently talking to Alarm.com servers.

- L1 - Flashes errors, if any.
- L2 - Communication with panel.
- L3 - Communication with radio unit.
- L4 - Signal level (0 to 5 bars).

**PowerSave Mode.** The module just powered up, or AC power is down, or AC power was recently restored and the battery is recharging. The module draws 10 mA while in PowerSave Mode. It is fully functional and will go into Connected Mode as soon as a signal needs to be sent. Pressing the 5 Key for 10 seconds or more will switch the module into Idle Mode and update the signal level reading. The system will go into Idle Mode every 2 hours to check for any incoming messages.

- L1 - Inactive.
- L2 - Communication with panel.
- L3 - Same flashing pattern as L2.
- L4 - Inactive.

**Connected Mode.** The module is currently talking to the Alarm.com servers. The module stays in connected mode for at least four minutes after reporting an event to Alarm.com, unless the 5 Key is pressed for 10 seconds or more, which will cause the module to go back to Idle Mode.

- L1 - Flashes errors, if any.
- L2 - Communication with panel.
- L3 - Communication with Alarm.com.
- L4 - Alternates two seconds on, then two seconds off.

**Sleep Mode.** The panel is not connected to AC power, or there is an AC power failure, and the battery level is low. The module will connect to Alarm.com to send a signal, but otherwise is in a state that draws almost no power.

**Troubleshooting: Special Key Presses**

Press any of the following panel keys for 10 seconds or more and the following information will be displayed on the panel LCD. Most messages are displayed for less than 30 seconds but can be cut short by pressing the # Key for 10 seconds.

Diagnostic Key Presses	
<b>1 Key</b>	10-digit module serial number. This number is needed to create the Alarm.com customer account.
<b>2 Key</b>	Module firmware version. (e.g. 4117a)
<b>3 Key</b>	15-digit SIM card number. You may be asked for this number by a technical support representative to verify that the module was activated on the GSM network.
<b>4 Key</b>	List of report types that the module will send to Alarm.com and to the central station. See <i>Report Types (4 Key)</i> .
<b>5 Key</b>	Wireless signal strength level and module status or error, if any (see <i>GSM Status and Signal Level (5 Key)</i> ). This key is also used to force the module to read the signal level.
<b>6 Key</b>	Battery voltage as read by the module, to two decimal places, and the AC power status. (e.g. Battery: 6.79v, AC Power OK)
<b>8 Key</b>	The GSM Frequency at which the radio is currently connected. "High" = 1900 MHz, "Low" = 850 MHz. The GSM Frequency that is being selected. The choices are: "Auto" (automatically chooses frequency with best signal level), "1900 MHz" and "850 MHz".

**Report Types (4 Key)**

Press the 4 Key for 10 seconds or more to get a list of the types of events that will be reported by the module. These types will be displayed on the keypad. Reports can be turned on or off via the Alarm.com Dealer web site and may depend on the customer service plan.

Reporting Bits (from Key 4)	
Codes not included in this table are for Alarm.com internal use only.	
<b>Tst</b> - Phone Test	<b>Pgm</b> - Panel Programming
<b>Ala</b> - Alarms	<b>Tpr</b> - Tamper
<b>Sys</b> - System Troubles	<b>Can</b> - Cancels
<b>Zon</b> - Sensor Trouble	<b>Nor</b> - Normal Activity
<b>Arm</b> - Arm/Disarm	<b>Pow</b> - Modem On Line
<b>Byp</b> - Sensor Bypass	<b>Png</b> - Pings
<b>Ac</b> - AC Power Failure	<b>C&amp;S</b> - Smash & Crash
<b>Pho</b> - Phone Failure	<b>Bat</b> - Panel Low Battery

**Note:** Certain report types are not included with all Alarm.com service plans. Contact Alarm.com for further information.

**GSM Status and Signal Level (5 Key)**

Press the 5 Key for 10 seconds or more to get the signal level and the module status or error, if any. The panel will display bars for the signal level (0 to 5) and a number (2 to 31) followed by the Mode it is in:



Module Status from 5 Key	
Idle	Most common state
Roaming	Roaming on partner network.
SIM Missing	Same as 2 flashes on L1
PowerSave Mode	AC Power is Down
Registering...	Same as 3 flashes on L1
Connection Error	Same as 4 Flashes on L1
Radio Error	Radio is not operating correctly, same as 5 flashes on L1
Server Error	Same as 8 flashes on L1
Connected	Currently talking to Alarm.com Servers
Connecting...	In the process of connecting to Alarm.com
Updating...	Updating Signal Level

Pressing the 5 Key for 10 seconds while the module is connected to Alarm.com (but not actively transmitting), or in PowerSave mode will allow the module to refresh its signal level reading. This can be useful during panel installation while looking for the best location, and when the module is likely to go in PowerSave mode because the transformer is unplugged, or because it's connected to Alarm.com when it cannot get a signal level reading.



## Improving wireless signal strength

For optimal wireless signal strength, follow these guidelines:

- Install the module above ground level, as high up as possible within the structure.
- Install the module near or adjacent to an outside-facing wall of the structure.
- Do not install the module inside a metal structure or close to large metal objects or ducts.
- Make sure to follow the antenna positioning guidelines that are included with the antenna. Certain antennas must be oriented a specific way in order to receive signals.
- Upgrade the antenna. If you are using the 1/4 wave antenna included with the GSM Gateway Module, upgrade to a remote cable antenna. Contact Alarm.com technical support for antenna options.

As you make changes to the module location or antenna to improve strength, you can press and hold the 5 key on the panel keypad to get an updated signal strength reading on the LCD display.

## Troubleshooting/Testing

- *The LEDs are not responding.*

Turn off the panel power and verify that the module is correctly inserted into the panel.

- *Module status LEDs do not turn on immediately after initial power up.*

You may need to wait a few minutes after power up for the module to register on the network.

- *Panel/sirens are beeping even though the system is not armed.*

Press touchpad status button and panel reports the trouble condition. Consult the panel manual for details.

**Note:** If the GSM module is powered down for a short period of time, buffered messages from Alarm.com may be received when module power is restored.

- *Panel will not perform GSM phone test.*

Only 10 GSM phone tests are allowed in a 24h period. If more GSM phone tests are required power cycle the control panel.

## Walking the Customer Through New User Setup on the Web

This section describes how to help your customer set up their website account, and only applies to Web/Interactive customers (you can skip this step if the customer is using Alarm.com for wireless signaling only).

Before the customer can configure their website account, the Alarm.com account for that customer must be created on the Dealer website, and the GSM module associated with the account must be installed successfully.

To log in and access the New User Setup Wizard, the customer can go to [www.alarm.com](http://www.alarm.com) (or custom

dealer website address) to complete the new subscriber setup procedure.

The customer will need the following:

- the website login and temporary password included on the Alarm.com *Welcome Letter* generated when the account was created by the Dealer;
- a list of their system sensors and touchpads with corresponding zone IDs; and
- at least one phone number and e-mail address where notifications can be sent.

**Note:** If not all sensors and touchpads were learned in before powering up the module, an updated sensor list must be requested by sending a command from the dealer site under **Support Options | Sensor List**.

**Note:** At least one sensor must be learned into the panel to complete the new subscriber setup.

## FCC compliance

This device complies with part 15 of the FCC rules. Operation is subject to the following conditions:

1. This device may not cause harmful interference.
  2. This device must accept any interference received, including interference that may cause undesired operation.
- Changes or modifications not expressly approved by the party responsible for compliance could void the user's authority to operate the equipment.

## Specifications

Compatible Simon XT panels with software versions 0.0.H and later  
 Power requirements 6V nominal  
 Standby current 30mA (10mA in power save mode)  
 Peak current 1.7A  
 Operating temperature 32 to 120°F (0 to 49°C)  
 Storage temperature -30 to 140°F (-34 to 60°C)  
 Max. relative humidity 90% non-condensing  
 Cellular network Quad-band GSM/GPRS  
 Dimensions (H x W) 4 1/16 x 1 7/8 in.  
 Listings FCC Part 15, PTCRB Cingular