



INDOOR/OUTDOOR  
**MINI DOME  
CAMERA**

INSTALLATION GUIDE  
**ADC-V821**

## Pre-Setup Checklist

- ADC-V821 camera  
(included)
- AC power adapter  
(included; required for non-PoE connections)
- Broadband (Cable, DSL, or Fiber Optic)  
Internet connection with router
- A computer or mobile device with Internet access
- An Ethernet / Cat5 cable
- Login and Password for the Alarm.com account  
to which you will add the camera

## Add the Camera to an Alarm.com Account

Complete these steps prior to installing the camera in its final location:

- 1 Connect the camera to the router via an Ethernet cable
- 2 If the Ethernet connection does not provide power, connect the camera to an AC power adapter and plug the adapter into a non-switched outlet.
- 3 Wait 2 minutes for the camera to connect to the Internet.
- 4 Add the device by either selecting the account in MobileTech OR by using a web browser and entering the following URL: [www.alarm.com/addcamera](http://www.alarm.com/addcamera)

- 5 Select the camera from the video list or type in its MAC address to begin adding the camera. The camera's MAC address is located on the base of the camera.
- 6 Follow the on-screen instructions to finish adding the camera. You may configure camera settings from the Customer Website.

**You can now power down the camera and install it in its final location using the included hardware.**

## Troubleshooting

- If you have issues connecting the camera to the account, power cycle the camera and try again.
- If issues persist, try resetting the camera to factory defaults by using the Reset button (located under the camera cover).
  - Ensure the camera is connected to a power supply.
  - Unscrew and remove the camera cover, being careful to not damage the connecting wires.
  - Press and hold the Reset button for 6 seconds or until the IR LEDs flash red.

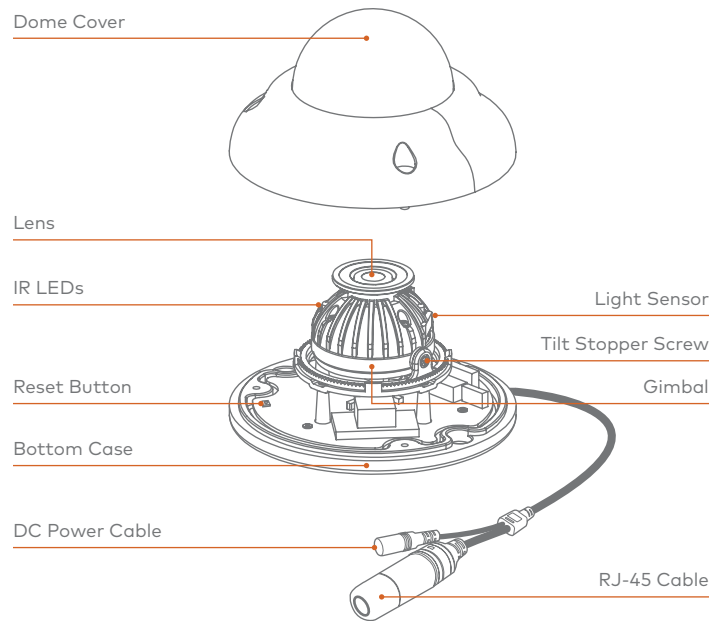

## Install the Camera

- 1 Choose a flat, sturdy location to mount the camera.
- 2 Remove the dome cover using the provided torx wrench.
- 3 Use the included mounting template to drill the mounting and cable holes. If you are installing on a hard ceiling or wall, only drill the cable hole.
- 4 Connect the Ethernet cable to the camera by feeding the cable through the appropriate hole. If required, connect the power cable. If you are installing on a hard ceiling or wall, skip to Step 8.

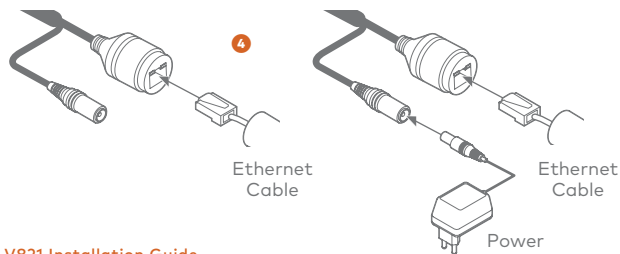

- 5 Secure the two mount bolts into the camera's bottom.
- 6 Insert the mount bolts into the template holes.
- 7 Affix the camera to the mounting surface by tightening the mount nuts to the mount bolts on the ceiling panel.

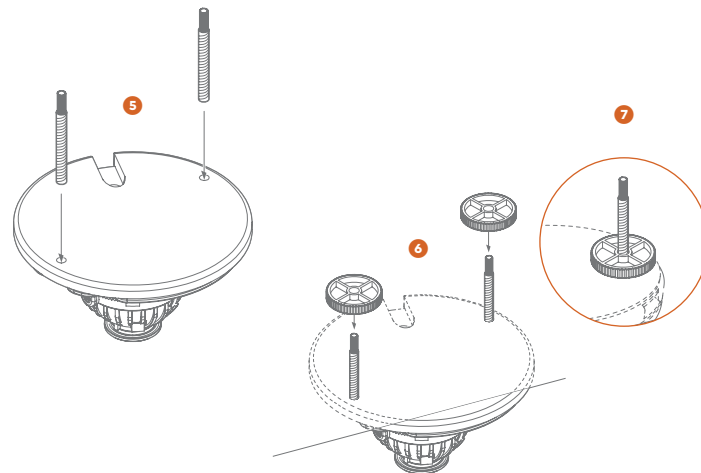

- 8 For hard ceiling and wall installations only: Attach the base of the camera to the mounting location using the included screws.
- 9 Rotate the camera gimbal as shown in the image to achieve the desired viewing angle. Loosening the tilt stopper screw (using a PH000 screwdriver) can make this process easier.

*Warning: Do not tilt the camera beyond 70 degrees.*

- 10 Re-attach the dome cover using the provided torx wrench.

*Warning: Ensure that the light sensor (see camera diagram) is visible when the camera cover is attached. If the light sensor is shielded by the cover, the camera will always be in night mode.*

- 11 Remove the protective film from the dome cover.

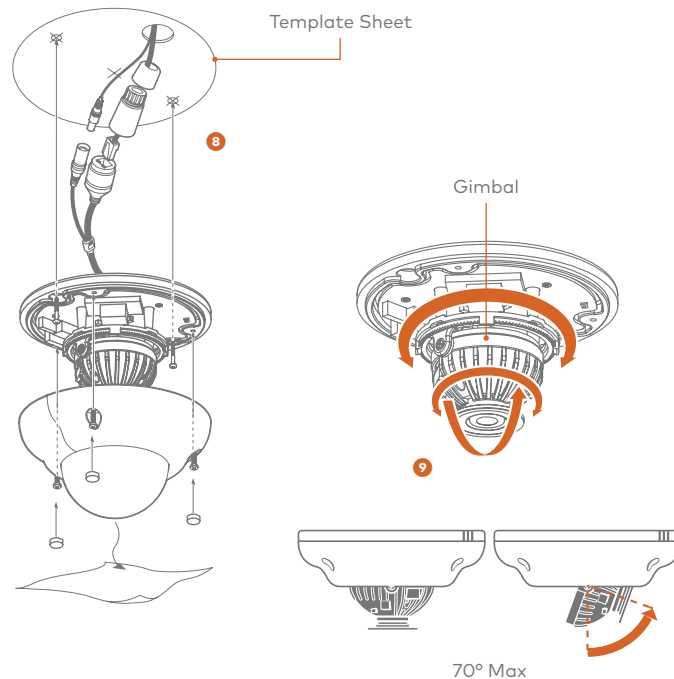









**ALARM.COM®**

© 2017 Alarm.com. All rights reserved.  
8281 Greensboro Drive, Suite 100  
Tysons, VA 22102

170518