

Honeywell Vista 20SE

Wiring M2M's MiNi/MQ Series Cellular Communicators and Programming the Panel

CAUTION:

- It is advised that an experienced alarm installer programs the panel as further programming may be required to ensure proper performance and use of the full functionality.
- Do not route any wiring over circuit board.
- Full panel testing, and signal confirmation, must be completed by the installer.

NEW FEATURE: For MiNi/MQ Series Communicators, the status of the panel can be retrieved not only from the status PGM but now also from the Open/Close reports from the dialer. Therefore, wiring the white wire and programming of the status PGM of the panel is optional.

Wiring the white wire is necessary only if the Open/Close reporting is disabled.

IMPORTANT NOTE: The Open/Close reporting needs to be enabled during the initial pairing procedure.

Wiring the MiNi Series communicators to Honeywell Vista 20SE

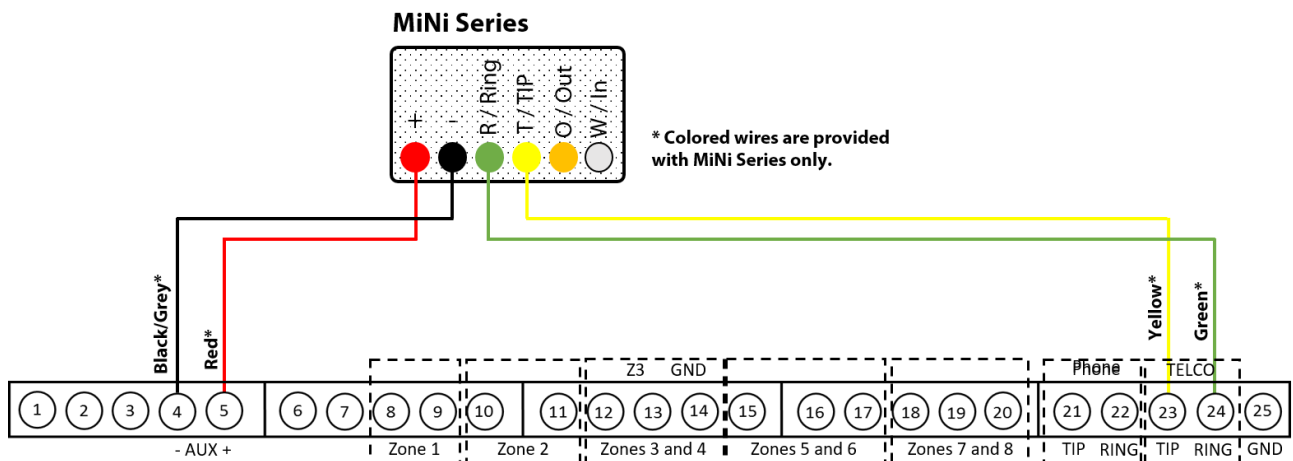

Wiring the MQ Series communicators to Honeywell Vista 20SE

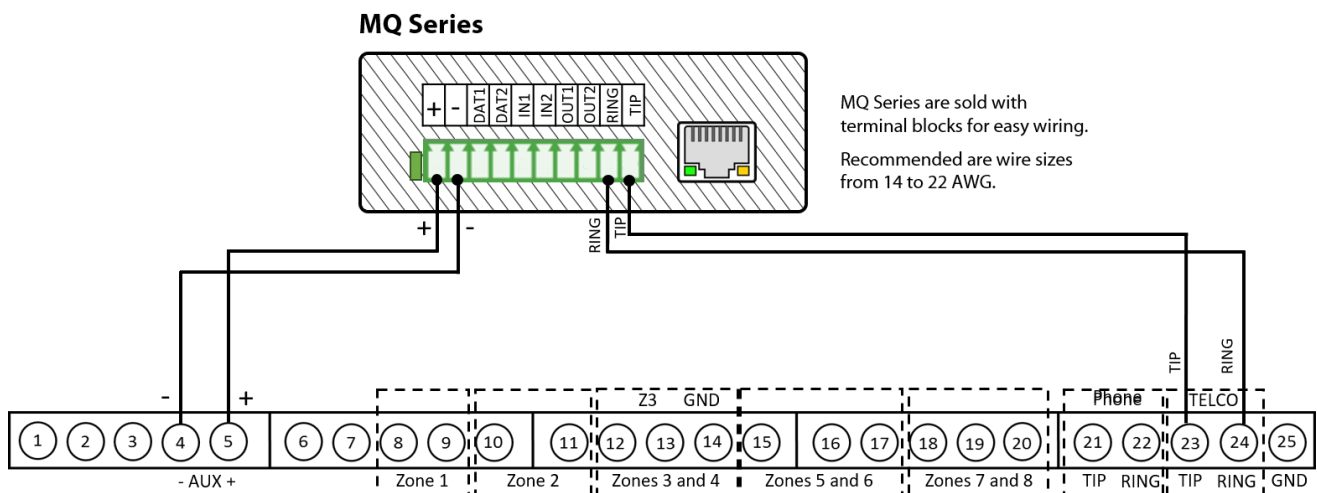

Programming the Honeywell Vista 20SE Alarm Panel via the Keypad

Enable Contact ID reporting:

Keypad Display	Keypad Entry	Action Description
DISARMED	4112800	To enter programming menu
Installer Code	*41	To start configuring primary phone number
Pri. Phone	123456*	Enter phone number value and press * to save and go back
Field?	*43	To start configuring "Part. 1 Primary Subs. Acct. No."
Pri Subld	1234	Enter account number value
Sec Subld	*47	To enter "Phone system select" menu
Phone Sys	1	To select "Tone Dial" and go back
Field?	*48	To enter "Report format" menu
Rep Form Pri/Sec	7*	To select "Ademco Contact ID" for primary phone number
Field?	*65	To go to "Open report code" setup
Open Rpt	1*	To enable reporting for "Open" event
Field?	*66	To go to "Arm Away/Stay Report Code" menu
Awy/Sty Rp	1, 1*	To enable reporting for "Away/Stay" events
Field?	*92	To go to "TLM" menu
Telco Monitor	0*	To disable TLM and save
#Rpt/Arm	*99	To exit programming mode