



333 Bayview Avenue, Amityville, New York 11701  
 For Sales and Repairs, (800) 645-9445  
 For Technical Service, (800) 645-9440 or visit us at  
<http://tech.napcosecurity.com/>

(Note: Technical Service is for security professionals only)  
 Publicly traded on NASDAQ Symbol: NSSC

© NAPCO 2020

# StarLink™ Commercial SLE-LTEVI-FIRE & SLE-LTEAI-FIRE Dual-Path Alarm Communicators INSTALLATION INSTRUCTIONS



WI2326E.bLF 11/20

## INTRODUCTION

The **SLE-LTEVI-FIRE** and **SLE-LTEAI-FIRE Dual-Path Alarm Communicators** are specifically designed to interface with FACP (Fire Alarm Control Panels) and to comply with UL 864. The communicators are equipped with two dry relays, one for a trouble output and one for an auxiliary output. The units are also equipped with four supervised inputs to report a Fire Alarm, a Fire Trouble, a Water Flow Alarm and a Supervisory Alarm, each triggered from the N/O and Common terminals of the associated FACP output relays. These communicators are for use as the primary means of communication with the central station and do not have backup mode capability. Dual Path Communicators can also be utilized as a Sole Path Cell Communicator. No POTS (Telco Line) connection permitted.

When connected to a FACP with one or two standard RJ-45 telephone inputs, the **SLE-LTEVI-FIRE** and **SLE-LTEAI-FIRE** provide two RJ-45 outputs to satisfy both telephone inputs. The primary RJ-45 output is supervised and reports a trouble to the central station upon any open or short on the primary RJ-45 wires that prevent reporting. The secondary telephone line is supervised by the FACP; when a line fault is detected, a trouble is reported to the central station through the primary telephone line.

The **SLE-LTEVI-FIRE** and **SLE-LTEAI-FIRE** are compatible with most 12 or 24VDC alarm control panels (always adhere to the documentation provided by the control panel manufacturer). Mount to a single-, dual-, or three-gang electrical box and route the wires through the back knock-out(s), or as specified by local codes. **See WI2140 for programming information.**

The **SLE-LTEVI-FIRE** and **SLE-LTEAI-FIRE** communicators use proprietary data-capture technology that captures the alarm report from the control panel and transmits the alarm signals to the SLE Control Center; the alarm signals are then forwarded to ANY central station via Contact ID or 4/2 via DACT from the NOC or Sur-Gard System II, Sur-Gard System V, Bosch D6100IPV6 or Bosch D6600 Receiver (with ITS-D6686 Ethernet Adapter) via TCP/IP using standard line security. The SLE Control Center reports a trouble signal in the event that the network does not receive the expected supervision signal from the wireless communicator. In addition, the **SLE-LTEVI-FIRE** and **SLE-LTEAI-FIRE** are powered directly from the control panel. **Note:** UL Listed for UL 1076 APOU Proprietary Alarm Systems and UL 365 APAW Police Connect when reporting to a UL Listed Central Station Receiver Listed for UL 1076 APOU Proprietary Alarm Systems or UL 365 APAW Police Connect, respectively. For TCP/IP only Bosch D6600 or D6100IPV6 for UL1076 and UL365 applications.

**SLE-LTEVI-FIRE & SLE-LTEAI-FIRE** - Commercial / Residential Fire LTE Network Compatible alarm capture Communicator. SIM card included. Red plastic enclosure. Rated nominal 12/24VDC input.

## ADDITIONAL COMPONENTS

In addition to the **SLE-LTEVI-FIRE** and **SLE-LTEAI-FIRE** listed above, the following sub-assemblies are available:

**SLE-WIFI-MODULE** - Allows your Napco StarLink™ device to connect to the Internet by means of a wireless (Wi-Fi) link, eliminating a wired Ethernet cable connection. **Note:** 7AH battery required when using the **SLE-WIFI-MODULE**. For more information, see WI2191.

**SLE-DLCBL** - Download Cable, 6 feet.

**SLE-ANTEXT30** - Extended antenna with 30 feet of cable

**SLE-ANTEXT50** - Extended antenna with 50 feet of cable

**SLE-ANTEXT75** - Extended antenna with 75 feet of cable

**SLE-ANTEXT100** - Extended antenna with 100 feet of cable

(Any suitable external cellular antenna is permitted by UL). Always follow the manufacturer's installation instructions. **Note:** Antennas are not Listed by UL.

## SPECIFICATIONS

**Electrical Ratings for +12V / 24V (powered by the control panel)\***

- Input Voltage: 10-25VDC regulated (power-limited output from Listed control panel Aux/Remote Fire Power).
- Input Current:
  - 10VDC standby: 162mA
  - 12VDC standby: 125mA
  - 15VDC standby: 110mA
  - 24VDC standby: 100mA
  - 25VDC standby: 100mA

**Wi-Fi Module:** (Optional) Add 40mA to the above. (With peak RF transmission current of 325mA).

**Electrical Ratings for the IN 1 Fire Input:**

- Input Voltage: 9-25VDC.
- Maximum Input Current: Up to 2mA from FACP NAC circuit

**Electrical Ratings for IN 2, IN 3, IN 4, and IN 5:**

(Inputs **IN 2, IN 3, IN 4, and IN 5** are Class B)

- Maximum Loop Voltage: 25VDC input.
- Maximum Loop Current: 1.7mA

## AGENCY LISTINGS



- UL 864 Standard For Control Units and Accessories For Fire Alarm Systems, 10th Edition
- UL 1610 Standard For Central-Station Burglar-Alarm Units
- UL 985 Standard For Household Fire Warning System Units
- UL 1023 Standard For Household Burglar-Alarm System Units
- UL 1076 APOU Proprietary Alarm Systems
- UL 365 APAW Police Connect
- NYC Fire Dept. Certificate of Approval #6317 & 6318

\*For Commercial Fire installations, a UL Listed Fire Alarm regulated power supply or FACP regulated auxiliary output is required.

- End of Line Resistor (EOLR) Value: 10K

### Electrical Ratings for PGM3 Output:

- Open Collector Output: Maximum Voltage 25VDC.
- Maximum PGM Sink Current: 50mA (up to 15VDC), 25mA (15.1VDC - 25VDC)

### Physical (W x H x D)

- Plastic Housing: 8 x 5<sup>-29/64</sup> x 1 1/2" (20.3 x 13.9 x 3.8cm)
- Mounting: Plastic housing includes three keyhole slots for triple gang boxes (see scale template on page 13);
- Antenna Length: 8.25" (21cm)

### Environmental

- Operating Temperature: 0°C - 49°C (32°F - 120°F)
- Humidity: Maximum 93% Non-Condensing
- Indoor / dry location use only

## TERMINAL DESCRIPTIONS

Configure all inputs and outputs using the Management Center screen (located at [www.NapcoNOC.com](http://www.NapcoNOC.com)). Located at the bottom of the StarLink radio PC board, the terminals are described as follows:

#### TB1: PWR (+10 - 25VDC)

(Refer to section "STEP 4: APPLY POWER")

#### TB2: PWR GND (-)

(Refer to section "STEP 4: APPLY POWER")

**TB3: PGM3 (-):** Open collector output. PGM3 is normally on (active low). When it is triggered (for example, a trouble is detected) it becomes open collector/high. To have a zone dedicated to an StarLink radio trouble, insert one side of the end of line resistor into this PGM3 terminal, and wire the other side of the resistor to the positive terminal of the zone.

**TB4: IN 1 (+):** Smart Channel input. Active high input for wiring to the control panel bell output. When this input detects a pulsing temporal 3 high, it sends a Fire alarm; a pulsing temporal 4 (CO Alarm), a CO alarm is sent. When used, these conductors must be run in conduit (max 20 feet for Commercial Fire, and 3 feet for Residential Fire). For this input to report to a central station, the StarLink radio must be

configured with the central station telephone number and correct reporting formats and codes. For more information, see WI2140 located at [www.NapcoNOC.com](http://www.NapcoNOC.com).

**TB5: IN 2 (+):** Fire Trouble input\*\*. Wire to FACP trouble relay N/O with parallel 10K EOLR at FACP.

**Note:** Inputs **IN 2**, **IN 3**, **IN 4** and **IN 5** can be supervised end-of-line resistor inputs that can be triggered with N/O or N/C relay contacts.

**TB6: IN 2 (-):** See **TB5**, above.

**TB7: IN 3 (+):** Fire Alarm input\*\*. Wire to FACP Fire Alarm relay N/O with parallel 10K EOLR at FACP.

**TB8: IN 3 (-):** See **TB5** and **TB7**, above.

**Secondary Telephone:** RJ-45 socket for FACP DACT connection.

**Primary Telephone:** RJ-45 socket for FACP DACT connection.

**TB9: IN 4 (+):** Supervisory Alarm input\*\*. Wire to FACP Supervisory relay N/O with parallel 10K EOLR at FACP.

**TB10: IN 4 (-):** See **TB5** and **TB9**, above.

**TB11: IN 5 (+):** Water Flow Alarm input\*\*. Wire to FACP Water Flow relay with parallel 10K EOLR at FACP.

**TB12: IN 5 (-):** See **TB5** and **TB11**, above.

**TB13: GND:** Earth ground terminal.

**Ethernet:** Connect the SLE Dual-Path radio communicator to your broadband modem, router or switch.

**Note:** The cable modem/router and switch (if any) at the premises requires standby power, therefore a UL 1481 / UL 864 or UL Listed ITE (*Information Technology Equipment*) UPS must be used at the premises to power these devices for a minimum of 24 hours.

**TB19: N/O OUT1:** Normally open. Dry contact Form C relay. Add shunt to lower two pins of JP1 for wet contacts.

**TB20: C OUT1:** Common. Dry contact Form C relay. Add shunt to lower two pins of JP1 for wet contacts (connects relay Common to system ground). Relay rated 30V AC/DC, 500mA.

**TB21: N/C OUT1:** Normally closed. Dry contact Form C relay. Add shunt to lower two pins of JP1 for wet contacts.

**TB22: N/O OUT2:** Normally open. Dry contact Form C relay.

**TB23: C OUT2:** Common. Dry contact Form C relay. Relay rated 30V AC/DC, 500mA.

**TB24: N/C OUT2:** Normally closed. Dry contact Form C relay.

## LED DESCRIPTIONS

The PC board contains several LED's, as follows:

### GREEN RF SIGNAL STRENGTH LED

Labeled "D3", this LED is located at the lower right corner of the PC board.

Every 30 seconds, the StarLink radio receiver section turns on and listens to the cell tower. Depending on the signal strength detected, it will blink the Signal Strength LED from 1 to 5 times, providing a signal strength indicator that is updated constantly and is always displayed.

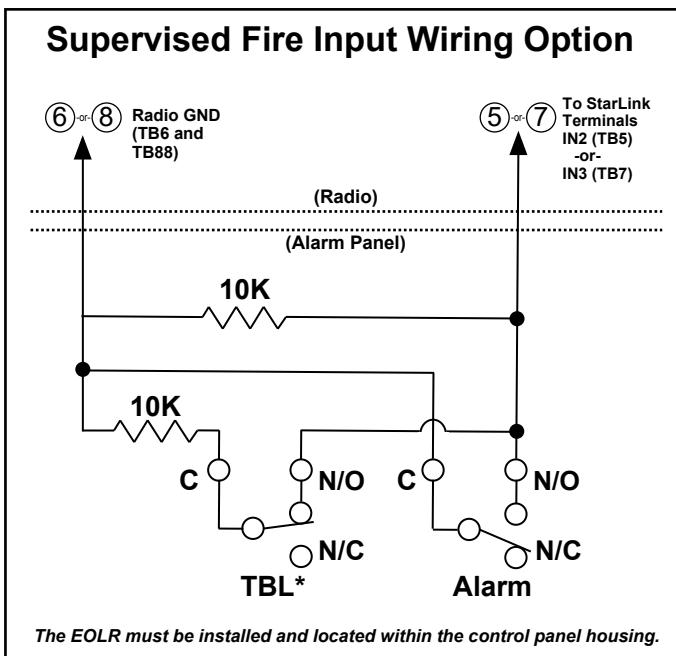

\*Reverse polarity / energized state.

\*\*Factory programmed options; may be changed at the NOC website ([www.NapcoNOC.com](http://www.NapcoNOC.com))

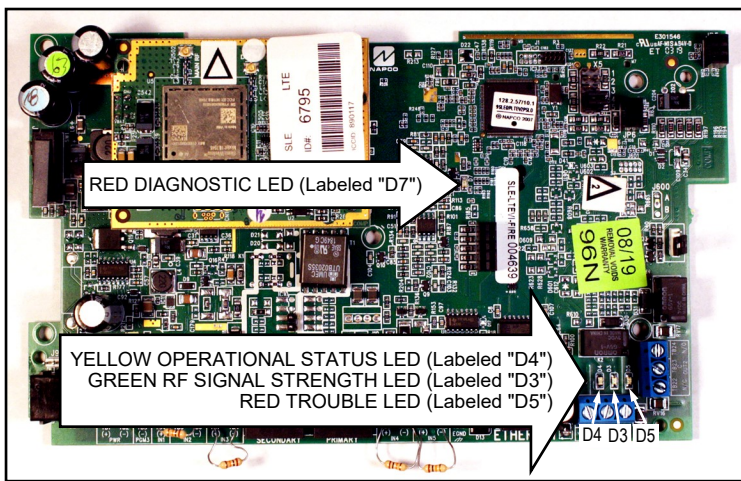

LED LOCATIONS

### Green LED Operation

Signal strength (as received by the radio) is displayed by this LED blinking 1 to 5 times at a constant rate (with a short delay between blink cycles). **Acceptable power level is greater than or equal to 2 blinks.**

### YELLOW OPERATIONAL STATUS LED

Labeled "D4", this LED is located at the bottom right of the PC board. Operation is as follows:

#### Normal Standby Condition:

- **Blinks on momentarily every 10 seconds:** Unit is in standby waiting for an alarm to report.

#### Processing Alarm Conditions:

- When processing an alarm, this LED will blink variably during each part of the process (dialing, handshaking, data transmission, etc.).

### RED TROUBLE LED

Labeled "D5", this LED is located at the bottom right of the PC board. Operation is as follows:

- **1 Blink:** Low Aux Power input voltage

- **2 Blinks:** Battery trouble
- **3 Blinks:** Alarm report Failed to Communicate (will restore only when the radio path is restored)
- **4 Blinks:** RF trouble (antenna connection or cellular registration)
- **5 Blinks:** Radio poll or check-in failure (radio and/or Ethernet). Either or both paths will trigger the trouble, but for the trouble to clear, unit requires both IP and radio polling/checkins to be operational
- **6 Blinks:** Unit disabled (reporting or control panel downloading not allowed)
- **7 Blinks:** Unit was shutdown and has no functionality; requires a restart (full power down and full power up sequence) to restore operation.
- **8 Blinks:** Telco Line Cut

### RED DIAGNOSTIC LED

Labeled "D7", this LED is located in the middle of the PC board. One blink indicates a weak or non-existent signal from the network (green LED is off). If this red LED is blinking in any other manner, please contact technical support.

### GREEN IP NETWORK CONNECTION LED

Labeled "D14" (or DS14), this LED is located to the right of the **ETHERNET** socket on the PC board. Operation is as follows:

**Off** = No network cable detected

**Fast Flash** = No IP connection (Occurs just after power on, while trying to obtain a IP address)

**Slow Flash** = Normal IP network operation

- **1 Blink:** Static IP
- **2 Blinks:** DHCP
- **3 Blinks:** Auto IP (if unable to acquire DHCP address, then after 5 minutes it will convert to Auto IP)

### RED IP NETWORK TROUBLES LED

Labeled "D16" (or DS16), this LED is located to the right of the **ETHERNET** socket on the PC board. Operation is as follows:

**Off** = No troubles

## NOTICE TO AUTHORITIES HAVING JURISDICTION, USERS, INSTALLERS, DEALERS, AND OTHER AFFECTED PARTIES

FIRE PROGRAMMING OPTION	PERMITTED IN UL864? (Y/N)	AVAILABLE SETTINGS	REQUIRED UL 864 SETTINGS
Unattended Remote Downloading	No	Enable / Disable	Disabled (Jumper 1 installed). Also required for Commercial installations. <b>Note:</b> See page 7 "Configuration Download / Firmware Updates" for jumper instructions.
IN2 and IN3 Unsupervised	Yes	Supervised / Unsupervised	Unsupervised using conduit within 20 feet of FACP (default). If not using conduit, install Jumpers 4 and 5 and EOL Resistors. Inputs 2 an 3 can be unsupervised with jumpers 4 and 5 removed; IN4 and IN5 always require EOLR.
7 Day Supervision, Radio to NOC	No	200 seconds, 5 minutes, 6 minutes, 60 minutes, 6 hours, 7 days	200 seconds, 5 minutes, 60 minutes. 6 Hours permitted in Commercial Fire UL 864 with Dual Path enabled.
Trouble on Radio or IP Path (Annunciate / Report)	Yes	Either Path or Both Paths	Either Path (annunciation and report of trouble).
Wi-Fi Module	Yes	Enable / Disable	May be enabled as a primary reporting path for Fire.

**Fast Flash** = No IP connection (occurs just after power on while trying to obtain a DHCP address)

**Slow Flashing:**

- **1 Blink:** No network cable detected
- **2 Blinks:** No access to the Internet
- **3 Blinks:** Ethernet failed to communicate
- **4 Blinks:** Ethernet poll / checkin fail
- **5 Blinks:** Wi-Fi is enabled, but **SLE-WIFI-MODULE** is not detected
- **6 Blinks:** Wi-Fi no access to the Internet
- **7 Blinks:** Wi-Fi failed to communicate
- **8 Blinks:** Wi-Fi poll / checkin failure
- **9 Blinks:** Wi-Fi serial data error or no serial data response
- **10 Blinks:** Wi-Fi Security / Authentication failed

**YELLOW IP NETWORK STATE LED**

Labeled "**D15**" (or **DS15**), this LED is located to the right of the **ETHERNET** socket on the PC board. Operation is as follows:

**Off** = No power

**Steady with 1 quick blink** off every 1.7 seconds when reporting signal to NOC

**Steady with 2 quick blinks** off every 1.7 seconds when downloading to control panel or the module

**Slow Flashing:**

- **1 Blink:** Ethernet Available
- **2 Blinks:** Wi-Fi Station Mode (normal operation)

**SUPPLYING POWER**

Control panels can provide power through their Auxiliary/Remote Fire Power terminals if the available standby current is reduced by the SLE standby power (refer to Electrical Ratings for +12V / 24V).

**Note:** The cable modem/router and switch (if any) at the premises requires standby power, therefore a UL 1481, UL 864 or ITE (*Information Technology Equipment*) Listed UPS must be used at the premises to power these devices for 24 hours (unless an engine driven generator is provided on the premises, then only 4 hours of UPS backup are required).

**JUMPER DESCRIPTIONS**

Jumper block labeled "**X5**"; from top to bottom, as detailed in the following table. **Note:** Contact ID is always available in response to a Contact ID handshake.

<b>Jumper Block "X5" Options</b> Jumper block labeled "X5" contains 5 jumper terminals; from top (labeled "1") to bottom (labeled "5") as follows:		
Jumper ON	Jumper Number	Jumper OFF
Tech on site must temporarily remove to download	1	Not permitted by UL 864
4/2 with Checksum Pulse Format*	2	4/2 Pulse Format*
Supervised inputs IN3 and IN2, respectively. EOLR(s) required, see page 2	4 and 5	Not permitted by UL 864 (UL 864 permits use of conduit within 20 feet of FACP in lieu of Supervision)

\*See table "NOTICE TO AUTHORITIES HAVING JURISDICTION..." on page 3.

The SLE series radios are compatible with 4/2 Pulse Dialing formats with 10pps, 20pps, and 40pps with and without checksum, either 1400Hz or 2300Hz handshake / kissoff. See table of formats on page 5.

Refer to WI2140 for selecting the required handshake / kissoff frequency in the NOC ([www.NapcoNOC.com](http://www.NapcoNOC.com)) set-up screens (as required by the control panel).

**NETWORK COVERAGE**

The StarLink radio constantly supervises the cell network coverage. When the StarLink radio detects a loss in network coverage, the StarLink radio must be configured to prompt the control panel to announce a Telco Line Cut failure trouble using the Management Center screen (located at [www.NapcoNOC.com](http://www.NapcoNOC.com)).

**INSTALLATION STEPS**

**STEP 1: ACCOUNT REGISTRATION**

Create a new account and register specific StarLink radio modules at [www.NapcoComNet.com](http://www.NapcoComNet.com). Accounts and modules registered via the Internet are enabled for activation within 24 hours.

**STEP 2: SELECT A MOUNTING LOCATION**

The mounting location should be indoors within the protected area and selected based on RF performance. It is HIGHLY recommended that the installer carefully adhere to the following recommendations BEFORE any wires are installed.

- Generally, high locations are best. DO NOT mount radio in basements or below grade as unpredictable performance may result.
- DO NOT mount the radio in non-climate controlled environments (i.e. attics may become extremely hot in summer, garages may become extremely cold in winter).
- Avoid mounting locations within 3 feet of AC power lines, fluorescent light fixtures, or large metal objects (air conditioners, metal garage doors, etc.) as these locations have been shown to have a detrimental effect on signal strength.
- A fair amount of care may be required to mount the radio so as to achieve an optimal RF path. The installer should spend as much time as needed to obtain the highest signal level possible.
  - a. **Before applying power, be sure to connect the antenna.** Temporarily connect power to the radio from a fully charged 12V (4AH minimum) battery. DO NOT mount the StarLink radio at this time. Press **Tamper** switch to send a signal.
  - b. Position the unit in the desired mounting location, with antenna oriented vertically. The signal strength is displayed by the Green "Signal Strength LED" labeled "D3" (located at the lower right corner of the PC board). The radio tower signal strength may fluctuate from day to day, therefore it is best to try to find a mounting location where the LED provides a **minimum of 2 blinks**.
  - c. Once a location has been selected based on signal coverage, permanently secure the unit using #8 screws (not supplied) in the two mounting holes.

**WARNING:** To ensure user safety and to satisfy FCC RF exposure requirements, this unit must be installed so that a minimum separation distance of 60cm (24") is always maintained between the antenna of the transmitting device and nearby persons.

**STEP 3: WIRING**

22-gauge wire may be used if mounted up to 50 feet from the control panel, and 18-gauge wire should be used for up to 100 feet. Reference the wiring diagrams further in this manual. See the section **CONTROL PANEL PROGRAMMING** further in this manual.

The wiring between the control panel and the StarLink radio is over several wires, as follows:

- **TB1: PWR**
- **TB2: PWR GND (-)**
- **TB21: N/C OUT1:** Wired to the (+) of a zone dedicated to monitoring the radio status. Should be programmed on Napco GEMC control panels as Monitor or Supervisory Zone.
- **TELCO PRIMARY** to FACP Telco 1 RJ-45 socket.
- **TELCO SECONDARY** to FACP Telco 2 RJ-45 socket.
- (Place **JP1** shunt on bottom two pins)
- **Optional:** Wire **IN2** with a 10K EOLR in parallel with the FACP trouble relay output **Common** and **N/O** (or in series with **Common** and **N/C**).

**Wiring Methods**

- Strip wire carefully to avoid exposed conductors after installation, etc.)
- Use of Listed wire, ensuring that all conductors are to be insulated for the maximum voltage of any conductor in the enclosure
- All wiring methods must be performed in accordance with NFPA70, Articles 725, and 800

**STEP 4: APPLY POWER**

- **Attach antennas before applying power !**
- Apply 12/24VDC to terminals 1 and 2.

**STARLINK RADIO RELATED EVENT REPORT CODES** (Contact ID by default)

EVENT	AREA	CONTACT ID		PULSE 4/2**
		CODE	ZONE #	
IN 1 Fire	0	E110	990	1A
IN 2 Trouble	0	E373	992	F2
IN 3 Fire	0	E110	993	1A
IN 4 Supervisory	0	E200	994	00
IN 5 Water Flow	0	E113	995	13
Low Battery/Voltage	0	E302	994	F4
Tamper Trouble	0	E341	995	F5
Reboot	0	E625	997	F7
IN 1 CO (Carbon Monoxide)	0	E162	998	18
Medical Alarm*		E100		
24 hour Aux. Alarm*		E150		
24 hour Aux. Restore*		R150		
Keypad Emergency Alarm*		E140		
A.C. Trouble*		E301		
Tel 1 Fail*		E351		
Fire Polling Report		E780	999	F9
Supv Failure Report		E788	000	D1 or D2
Tip/Ring Wiring Fault Report		E789	000	F2
Path Test Report		E602	890	77

\*Not generated by the StarLink radio.

\*\*See table "NOTICE TO AUTHORITIES HAVING JURISDICTION..." on page 3.

**Cover Tamper Switch**

The SLE series radios in the plastic housings are provided with a front tamper switch. **Note:** The tamper switch on the radio PC board is always functional and requires no programming.

**SIGNALS ORIGINATED AT THE NOC**

NOC Originated Alarms	Contact ID Event Data Sent	Pulse Format Event Code Sent	Initiated By	Comments
Supervisory Fail	E356 A00 Zn000	99	Automatically by NOC if fail to receive any signal from StarLink radio within Supervisory Timeout duration.	For Auto Enroll, uses captured telephone number, Sub ID and format. For Dealer Programmed, uses entered telephone number, Sub ID and format.
Press to Send Test Signal	E601 A00 Zn000	98	Manually by dealer from the Management Center <b>Signal Log</b> screen (located at <a href="http://www.NapcoNOC.com">www.NapcoNOC.com</a> ). Sends test into CS receiver.	Same comment as above.
Press to Send Radio Test	Not Applicable Nothing sent to CS receiver	Not Applicable	Manually by dealer from the Management Center <b>Checkins</b> screen (located at <a href="http://www.NapcoNOC.com">www.NapcoNOC.com</a> ). Sends a command to the StarLink radio to force a check-in to the NOC.	----

## STEP 5: SIGNAL VERIFICATION

After triggering channels, use the StarLink radio Signal Verification to ensure that the StarLink radio Network has properly received the signals.

- **Verify Online:** To verify that the signals have been received by the StarLink radio Network online, go to [www.NapcoNOC.com](http://www.NapcoNOC.com), log in with your Username and Password, enter your **Company ID** number and the StarLink **Radio Number**, then click **Signal Log**.

**IMPORTANT:** Verify that the signals transmitted by the StarLink radio have been properly received by your central station before leaving the premises.

**NOTE:** This equipment has been tested and found to comply with the limits for a Class B Unintentional Radiator, pursuant to Part 15 of the FCC Rules. These limits are designed to provide reasonable protection against harmful interference in a residential installation. This equipment generates, uses, and can radiate radio frequency energy and, if not installed and used in accordance with the Instruction Manual, may cause harmful interference to radio communications. However, there is no guarantee that interference will not occur in a particular installation. If this equipment does cause harmful interference to radio or television reception, which can be determined by turning the equipment off and on, the user is encouraged to try to correct the interference by one of more of the following measures: 1. Reorient or relocate the receiving antenna; 2. Increase the separation between the equipment and receiver; 3. Connect the equipment into an outlet on a circuit different from that to which the receiver is connected; 4. Consult the dealer or an experienced radio/TV technician for help.

## NAPCO GEMINI C-SERIES (GEMC) CONTROL PANEL PROGRAMMING

To program the central station receiver reporting format, use PCD-Windows Quickloader download software. Open the **Digital Communications** screen, **Central Station Receivers** tab, as shown in the following image:

A "Point ID" (also called "Contact ID") receiver format programming example:

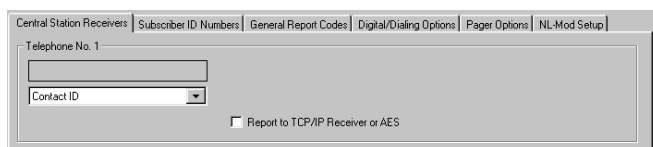

The radio can transmit to any central station capable of receiving SIA Contact ID or 4/2 via DACR technology or the DSC Sur-Gard Model System II or Sur-Gard System V central station receivers, Bosch D6100IPV6 or Bosch D6600 Receiver (with ITS-D6686 Ethernet Adapter) via TCP/IP using standard line security.

**Note:** A receiver reporting format must be entered for each telephone number used, but each telephone number may be assigned a different format.

**CAUTION:** The installer should always be certain an area code is programmed into the control panel.

**Optional:** If you wish the StarLink radio to report a code and zone number (Contact ID by default) to the central station in response to a triggered input event, see the table on

page 5. **Note:** These event codes and zone numbers can be changed from the Management Center screen (located at [www.NapcoNOC.com](http://www.NapcoNOC.com)).

Upon alarm, the NOC can optionally send an SMS message to a third party that includes the appropriate Contact ID alarm code, including the zone or user number, if applicable. The "**STARLINK RADIO RELATED EVENT REPORT CODES**" table also includes the most common Contact ID alarm codes.

## Programming StarLink Radio Troubles

It is required that if a StarLink radio or control panel trouble is detected, that it is reported to the central station.

When the StarLink radio detects and sends a trouble to the control panel, the control panel must be programmed to announce this trouble. The radio can detect multiple troubles as indicated by the "Red Trouble LED" ("**D5**"). For these troubles to be announced at the control panel, there are several methods, some of them are configurable at the Management Center screen ([www.NapcoNOC.com](http://www.NapcoNOC.com)):

Wire the radio **OUT1** relay to a dedicated control panel zone (input) to announce the trouble. Two wiring options are available:

- Activate the trouble with an open by wiring the EOLR in series with the **Common** and **N/C** of the **OUT1** relay;
- Activate the trouble with a short by wiring the EOLR in parallel with the **Common** and **N/O** of the **OUT1** relay

The radio must also report this trouble to the central station. With NAPCO GEMC series control panels, wire the zone as indicated in the wiring diagrams further in this manual. Optionally, the FACP trouble relay can be used to trigger a report to the central station.

Wire the FACP trouble relay to **IN2; Common** and **N/O** terminals in parallel with a 10K EOLR. With Gemini C-Series (GEMC) control panels, we recommend using the Fire Aux Relay. Program the Fire Aux Relay to activate as a trouble relay. Wire this relay to the StarLink module **IN 2** terminal; by wiring the EOLR in parallel with **Common** and **N/O** of the **OUT1** relay. **Note:** We recommend using the text "Radio Trouble" as the Zone Description.

## StarLink Radio Supervision

If the two Telco wires (DACT interconnect wiring to the radio) between the StarLink radio and the control panel are cut or otherwise disconnected, the control panel must detect and generate a local trouble indication. Program the control panel for telephone supervision. Program the StarLink radio using the Management Center **Advanced Features** screen (at [www.NapcoNOC.com](http://www.NapcoNOC.com)) to enable **Tip/Ring Wiring Fault Report**. Refer to wiring diagram.

## Supervision Time Schedule Considerations

If a status change (alarm trouble, etc.) is transmitted, the radio supervision timer is restarted.

For example, if a status change is sent, the next regular supervision transmission will occur at the interval determined by your rate plan.

## Configuration Download / Firmware Updates

**Technician on site required.**

For Commercial Installations a technician is required to be

on site during any reprogramming of the radio or control panel and must perform / re-perform acceptance testing. To perform a download or update the radio firmware, jumper 1 must be removed. UL requires that the jumper be replaced after the download is complete. **Failure to replace the jumper would allow downloads to the radio without a technician on-site.**

For Residential installations jumper 1 may be removed to permit uploading and downloading without a technician on site, however, the dealer is responsible for ensuring the system is operating correctly after any downloads or changes to the system.

### NYC Fire Department Requirements

1. All uses, configurations, arrangements and functions, applications and installations shall comply with the provisions of New York City Construction Codes, specifically Building Code Chapter 9 & 1RCNY §3616-04. Further, the installation shall be in accordance with applicable provisions of New York City Fire Code, New York City Electrical Code, manufacturer's installation requirements, and UL Standard 864.
2. When used Dual Path LTE Communicator (IP and Cellular) for Central Station communication both primary and secondary channels of communication shall be required and shall meet the conditions of 4.1 – 4.7. IP communication shall be used as primary channel of communication with Central Station and Cellular Communicator shall be used as the secondary channel of communication or in reverse order: Cellular Communicator as primary and Internet connection as the secondary channel.
  - a. Each communication channel shall be monitored for integrity at intervals not exceeding 24 hours.
  - b. Failure any channel of communication shall be annunciated at the protected premises within 5 minutes of failure.
  - c. When any channel of communication has failed, a trouble signal shall be sent to Central Station within 5 minutes of failure by the remained active channel.
- d. Reliability of the signal shall be achieved by any of the following:
  - Signal repetition - multiple transmissions repeating the same signal
  - Parity check - a mathematical check sum algorithm of a digital message that verifies correlation between transmitted and received message
  - An equivalent means that provides a certainty of 99.99 percent that the received message is identical to the transmitted message
- e. The maximum duration between the initiation of an alarm signal at the protected premises, transmission of the signal, and subsequent display and recording of the alarm signal at the Central Station shall not exceed 90 seconds
- f. A spare Central Station Receiver shall be provided at the Central Station and shall be able to be switched into the place of a failed unit within 30 seconds after detection of failure
- g. All applicable requirements of Federal Communications Commission (FCC) shall be complied with.
3. When used DACT for Central Station communication, two means of communication are required. The primary channel shall be telephone line. Cellular or internet communication shall be limited for the secondary means of communication and comply with 26.6.3 NFPA 72, 2010 edition. Another telephone line also may be used as secondary mean of communication.
4. The above-referenced equipment shall be used only with listed fire alarm control panels and devices, with which the compatibility has been determined by UL Listing Report
5. Only enclosures painted red in color shall be used.
6. Underwriters Laboratories Inc.'s listing requirements and limitations shall be complied with.

# Wiring Diagram for Generic FACP's without TELCO RJ Sockets

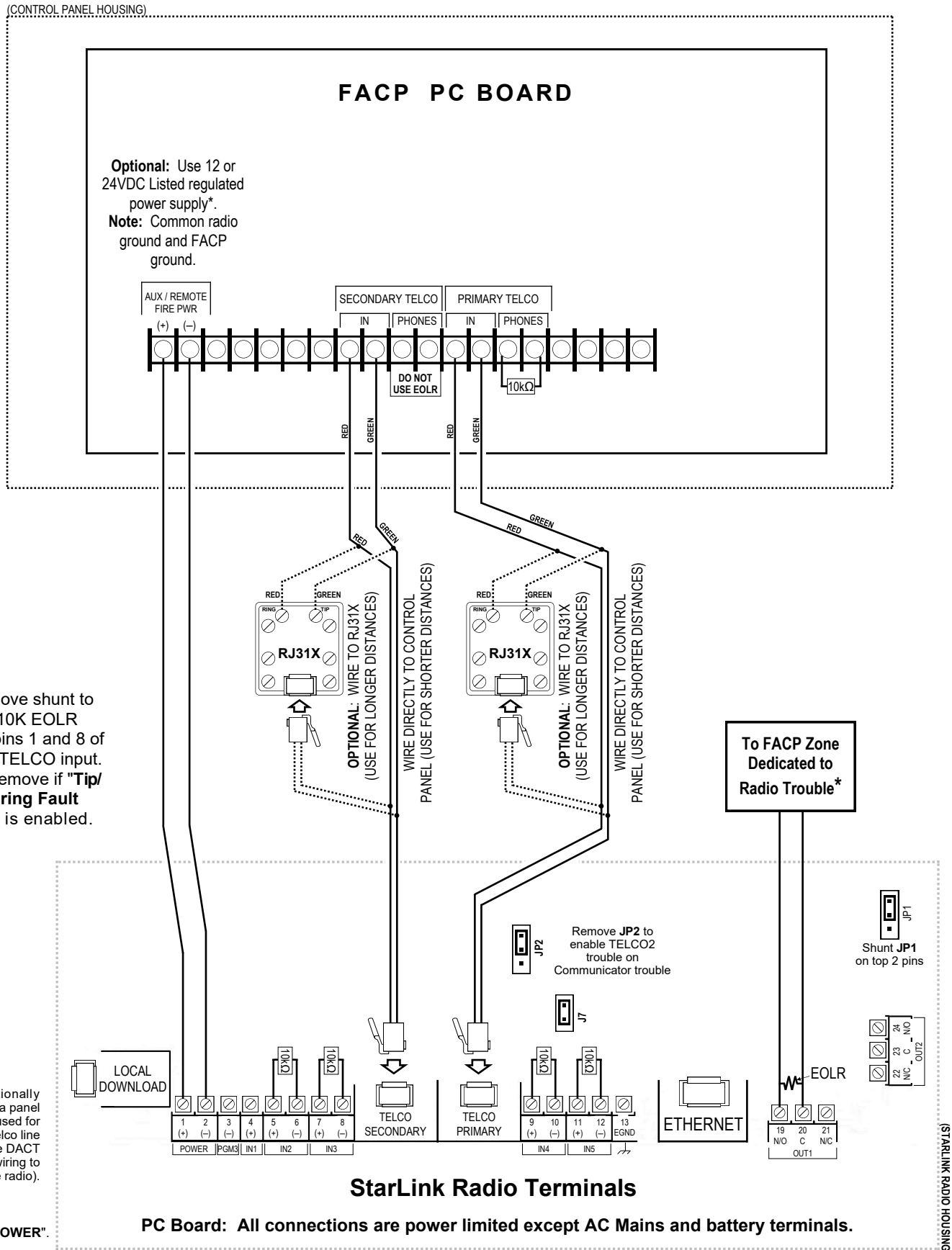

Refer to section "SUPPLYING POWER".

\* Not required if JP2 shunt is removed and FACP monitors TELCO 2.



# Wiring Diagram for Generic FACP's with TELCO RJ Sockets

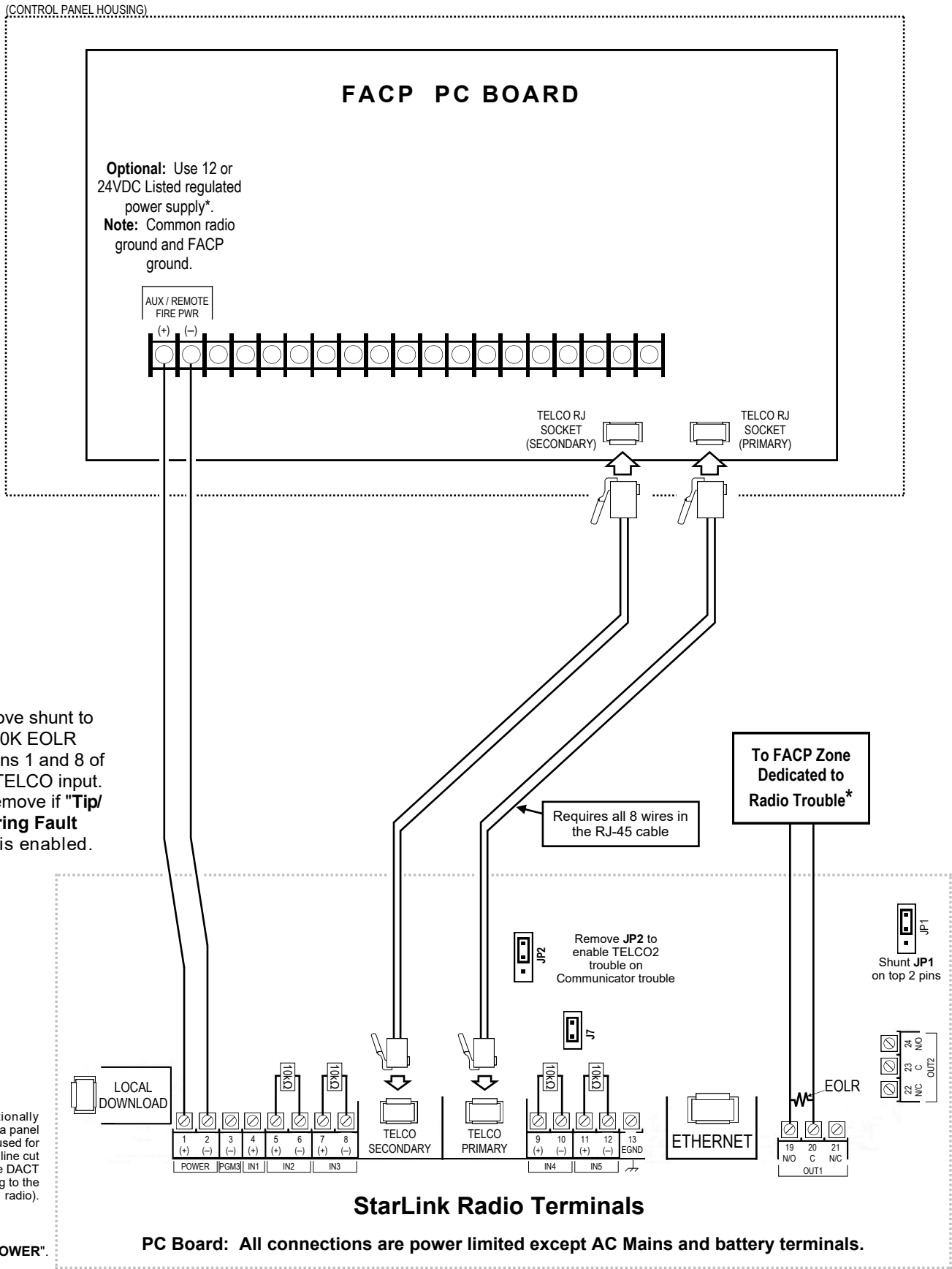

Refer to section "SUPPLYING POWER".

\*Not required if JP2 shunt is removed and FACP monitors TELCO 2.

(STARLINK RADIO HOUSING)

# Wiring Diagram for FACP Relay Trigger Input Reporting

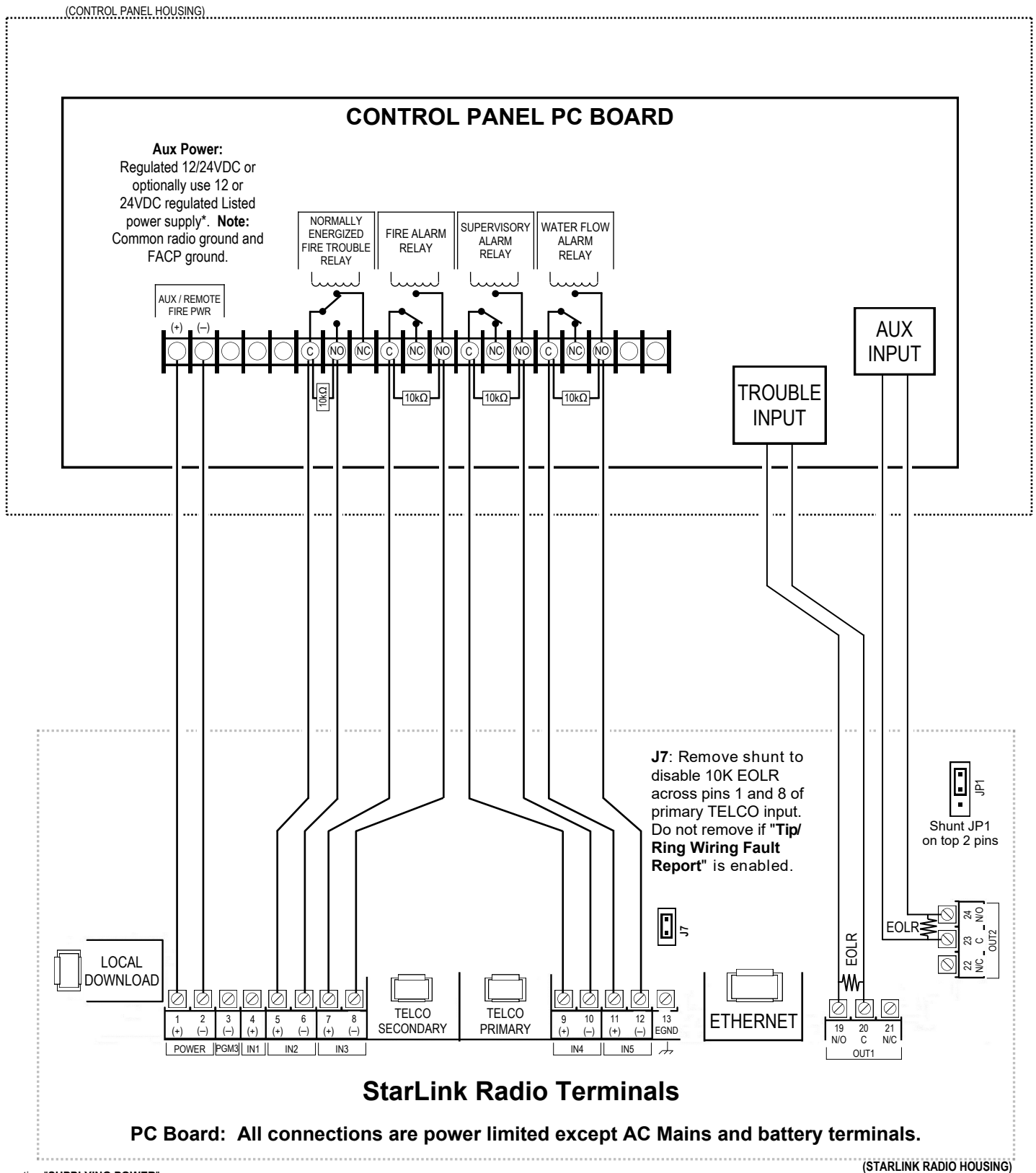

Refer to section "SUPPLYING POWER".

# Wiring Diagram for GEMC-32, GEMC-96, GEMC-128 and GEMC-255 Control Panels

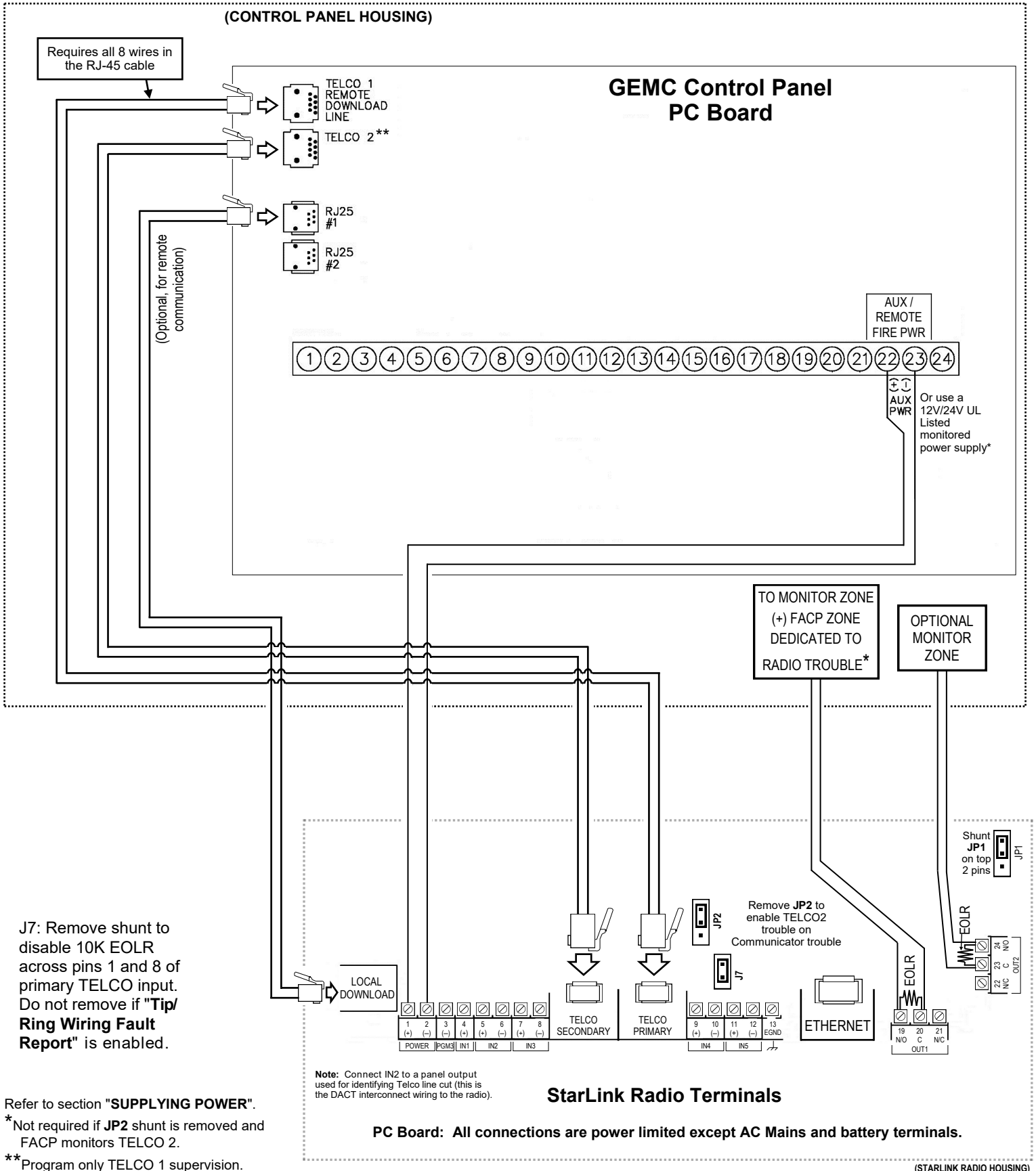

J7: Remove shunt to disable 10K EOLR across pins 1 and 8 of primary TELCO input. Do not remove if "Tip/Ring Wiring Fault Report" is enabled.

Refer to section "SUPPLYING POWER".

\*Not required if JP2 shunt is removed and FACP monitors TELCO 2.

\*\*Program only TELCO 1 supervision.

(STARLINK RADIO HOUSING)

This page intentionally left blank.

# Housing Template (1:1 Scale)

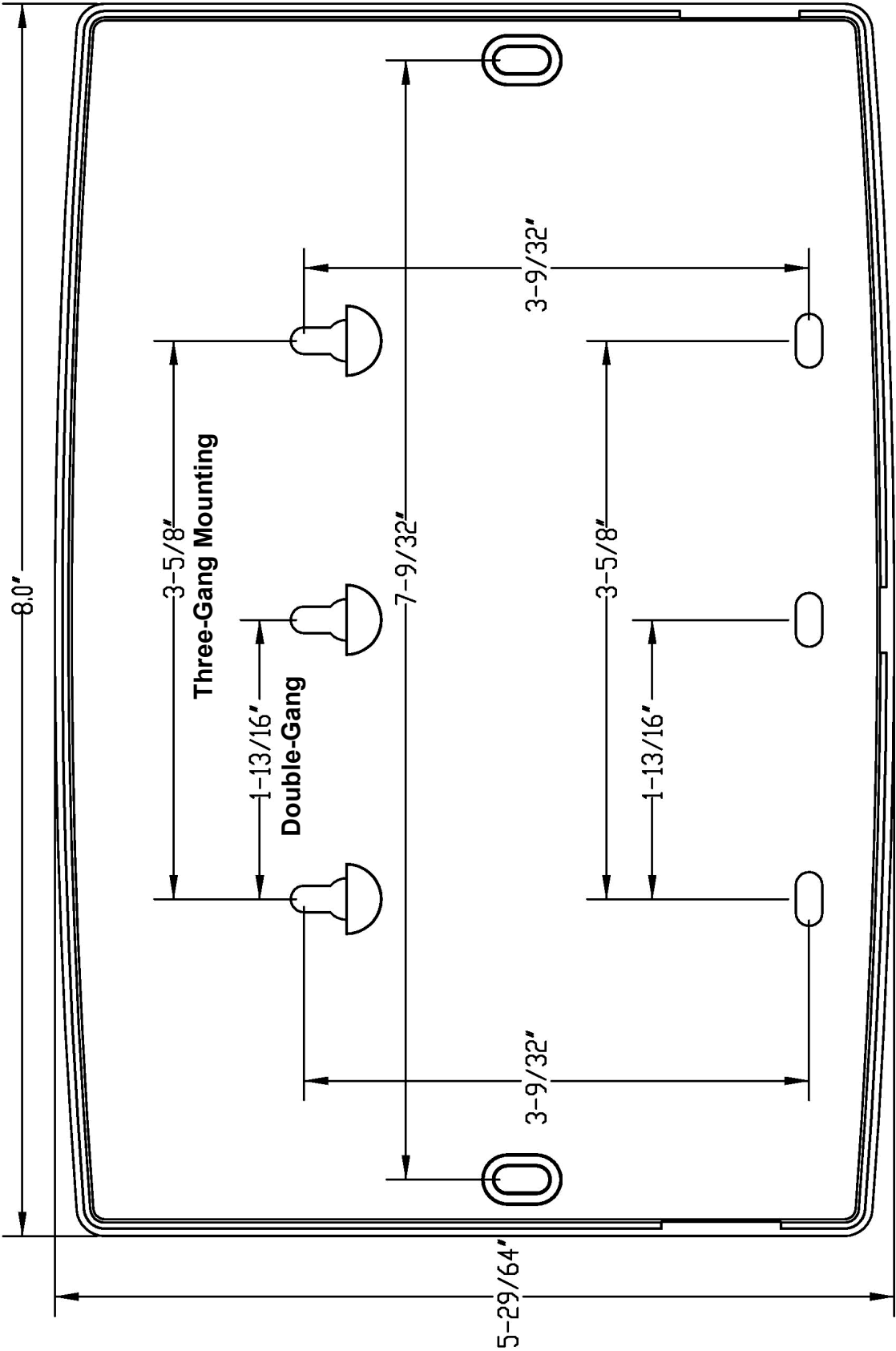

This page intentionally left blank.

# 4/2 Pulse Dialing Format Compatibility

**Note:** The SLE Series Radios are compatible with any Listed 4/2 Receiver such as the Ademco 685.

Name	Format Type	Handshake Frequency	Speed
Ademco Slow	4/2	1400 Hz or 2300Hz	10pps
Ademco Slow	4/2 checksum	1400 Hz or 2300Hz	10pps
Radionics Slow	4/2	2300Hz	10pps
Radionics Slow	4/2 checksum	2300Hz	10pps
Silent Knight Fast	4/2	1400 Hz or 2300Hz	20pps
Silent Knight Fast	4/2 checksum	1400 Hz or 2300Hz	20pps
Radionics Fast	4/2	2300Hz	40pps
Radionics Fast	4/2 checksum	2300Hz	40pps
Universal High Speed	4/2	1400 Hz or 2300Hz	40pps
Universal High Speed	4/2 checksum	1400 Hz or 2300Hz	40pps

**REN = 0.** The *Ringer Equivalence Number (REN)* indicates the maximum number of devices allowed to be connected to a telephone interface. The termination of an interface may consist of any combination of devices subject only to the requirement that the sum of the **RENs** of all the devices not exceed five (5).

## Alternate Telco Line to Alarm Panel Supervision

The following wiring and programming method allows an existing FACP to use its two telephone connections (primary and secondary) for supervision and central station reporting through the StarLink SLE-LTEVI-FIRE radio. By removing the **JP2** shunt and enabling the feature "**Tip/Ring Wiring Fault Report**", when any radio trouble is detected, the StarLink radio will remove voltage from the secondary telephone output, triggering the FACP to locally annunciate the Telco trouble and report the trouble to the central station. **Note:** Some FACPs require **J7** shunt to be removed for Primary Phone line to restore correctly.

## IMPORTANT WIRING METHODS



**For single-conductor terminal blocks** (like the type shown at left), to terminate more than one conductor to a terminal, use the wiring methods shown at right:

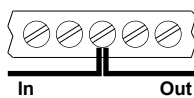

Incorrect

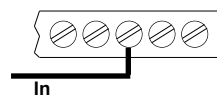

Correct -- Single incoming and/or pigtail with wire nut / crimp connectors

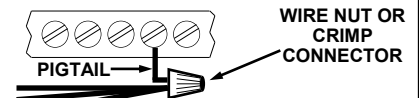

**For "barrier" type terminal blocks** (like the type shown at left), to terminate two conductors to a terminal, use the wiring methods shown at right:

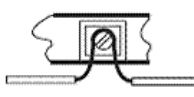

Incorrect

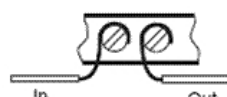

Correct -- Separate incoming and outgoing conductors



**To terminate more than two conductors** or conductors of different wire sizes to a terminal, use the "pigtail" type wiring method as shown at right. Use insulated wire for the pigtail, and firmly secure the conductors to the pigtail using an appropriate wire nut or crimp connector for the number and gauge of conductors used.

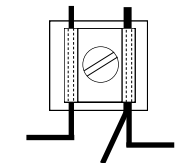

Incorrect

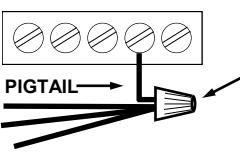

Correct -- Use pigtail and wire nut / crimp connector

# NAPCO LIMITED WARRANTY

NAPCO SECURITY TECHNOLOGIES, INC. (NAPCO) warrants its products to be free from manufacturing defects in materials and workmanship for *thirty-six months* following the date of manufacture. NAPCO will, within said period, at its option, repair or replace any product failing to operate correctly without charge to the original purchaser or user.

This warranty shall not apply to any equipment, or any part thereof, which has been repaired by others, improperly installed, improperly used, abused, altered, damaged, subjected to acts of God, or on which any serial numbers have been altered, defaced or removed. Seller will not be responsible for any dismantling or reinstallation charges.

THERE ARE NO WARRANTIES, EXPRESS OR IMPLIED, WHICH EXTEND BEYOND THE DESCRIPTION ON THE FACE HEREOF. THERE IS NO EXPRESS OR IMPLIED WARRANTY OF MERCHANTABILITY OR A WARRANTY OF FITNESS FOR A PARTICULAR PURPOSE. ADDITIONALLY, THIS WARRANTY IS IN LIEU OF ALL OTHER OBLIGATIONS OR LIABILITIES ON THE PART OF NAPCO.

Any action for breach of warranty, including but not limited to any implied warranty of merchantability, must be brought within the six months following the end of the warranty period. IN NO CASE SHALL NAPCO BE LIABLE TO ANYONE FOR ANY CONSEQUENTIAL OR INCIDENTAL DAMAGES FOR BREACH OF THIS OR ANY OTHER WARRANTY, EXPRESS OR IMPLIED, EVEN IF THE LOSS OR DAMAGE IS CAUSED BY THE SELLER'S OWN NEGLIGENCE OR FAULT.

In case of defect, contact the security professional who installed and maintains your security system. In order to exercise the warranty, the product must be returned by the security professional, shipping costs prepaid and insured to NAPCO. After repair or replacement, NAPCO assumes the cost of returning products under warranty. NAPCO shall have no obligation under this warranty, or otherwise, if the product has been repaired by others, improperly installed, improperly used, abused, altered, damaged, subjected to accident, nuisance, flood, fire or acts of God, or on which any serial numbers have been altered, defaced or removed. NAPCO will not be responsible for any dismantling, reassembly or reinstallation charges.

This warranty contains the entire warranty. It is the sole warranty and any prior agreements or representations, whether oral or written, are either merged herein or are expressly cancelled. NAPCO neither assumes, nor authorizes any other person purporting to act on its behalf to modify, to change,

or to assume for it, any other warranty or liability concerning its products.

In no event shall NAPCO be liable for an amount in excess of NAPCO's original selling price of the product, for any loss or damage, whether direct, indirect, incidental, consequential, or otherwise arising out of any failure of the product. Seller's warranty, as hereinabove set forth, shall not be enlarged, diminished or affected by and no obligation or liability shall arise or grow out of Seller's rendering of technical advice or service in connection with Buyer's order of the goods furnished hereunder.

NAPCO RECOMMENDS THAT THE ENTIRE SYSTEM BE COMPLETELY TESTED WEEKLY.

**Warning:** Despite frequent testing, and due to, but not limited to, any or all of the following; criminal tampering, electrical or communications disruption, it is possible for the system to fail to perform as expected. NAPCO does not represent that the product/system may not be compromised or circumvented; or that the product or system will prevent any personal injury or property loss by burglary, robbery, fire or otherwise; nor that the product or system will in all cases provide adequate warning or protection. A properly installed and maintained alarm may only reduce risk of burglary, robbery, fire or otherwise but it is not insurance or a guarantee that these events will not occur. CONSEQUENTLY, SELLER SHALL HAVE NO LIABILITY FOR ANY PERSONAL INJURY, PROPERTY DAMAGE, OR OTHER LOSS BASED ON A CLAIM THE PRODUCT FAILED TO GIVE WARNING. Therefore, the installer should in turn advise the consumer to take any and all precautions for his or her safety including, but not limited to, fleeing the premises and calling police or fire department, in order to mitigate the possibilities of harm and/or damage.

NAPCO is not an insurer of either the property or safety of the user's family or employees, and limits its liability for any loss or damage including incidental or consequential damages to NAPCO's original selling price of the product regardless of the cause of such loss or damage.

Some states do not allow limitations on how long an implied warranty lasts or do not allow the exclusion or limitation of incidental or consequential damages, or differentiate in their treatment of limitations of liability for ordinary or gross negligence, so the above limitations or exclusions may not apply to you. This Warranty gives you specific legal rights and you may also have other rights which vary from state to state.