

LIMITED WARRANTY  
Mtroniks Ltd. guarantee this product to be free from factory defects for 24 months from purchase date, verified by receipts. This does not cover suitability for specific applications, components worn by use, tampering, incorrect connection, alteration to original connectors, switches or wires (apart from the fitting of an in-line fuse), damage to batteries or other equipment through use, misuse or shipping damage. Our liability will not exceed the cost of the product. By using this ESC, the user accepts all liability. We reserve the right to modify this guarantee without notice.  
Copyright © Mtroniks Ltd. 2014

## INSTALLING YOUR VIPER ESC

Positioning of your ESC in the model

Mount the 24V VIPER HV ESC as far away as possible from the receiver, using double sided tape or velcro. Keep the thick power wires away from the antenna and other thin wires to avoid interference problems (See Fig.1 for example install). The antenna should come straight out of the receiver into the antenna tube and up out of the model. Do not attempt to use any part of the model as an antenna!

Make sure your motor is fitted with two (2) motor capacitors (0.1uF) - one from the negative terminal to the can and one from the positive terminal to the can.

Wiring up of ESC in model (See Fig.1)

The 24V VIPER HV ESCs are supplied with Tamiya style plug and bullet connectors at the factory.

Colour coding for wires:

**Black=Batt -ve, Red=Batt +ve, Blue=Mot -ve, Yellow=Mot +ve**

**NOTE: ALWAYS DISCONNECT ESC FROM BATTERY CELLS WHEN NOT IN USE!**

We **STRONGLY** advise fitting an in line fuse in the positive battery wire between the cells and the ESC. (Usually 5A lower than the ESC's stated limit. eg.. 10A fuse for a 15A ESC)

The 24V Viper HV controllers are capable of handling very large amounts of power and it is not safe to use them without fitting a suitable fuse.

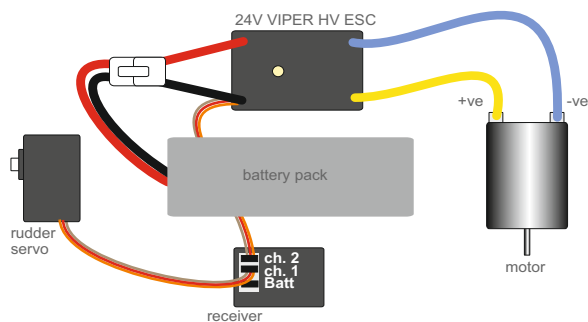

Fig.1 - installation diagram

# 24V VIPER HV INSTRUCTION SHEET AND WARRANTY

**PLEASE READ & FULLY UNDERSTAND THE INSTRUCTIONS & WARRANTY BEFORE USE**

## Receiver Lead Connections

The receiver lead on the 24V VIPER HV ESC is the universal JR type, see chart below.

For some receivers you may need to swap the red and brown wires in the plug.

RECEIVER TYPE	SIGNAL	+VE	-VE
	POSITION 1	POSITION 2	POSITION 3
FUTABA, SANWA, KO	White/Blue	Red	Black
HI-TEC	Yellow	Red	Black
JR, GRAUPNER, KYOSHO	White/Orange	Red	Brown
ACOMS	Yellow	Red	Black
AIRTRONICS	White/Orange	Black	Red

## ESC SET-UP

Before beginning set-up you need to connect up your 24V VIPER HV ESC as in Fig.1.

(When plugging the ESC's receiver lead into the receiver make sure that the signal wire - orange - is facing inwards).

Calibrating the ESC to your transmitter

Now that you have installed your ESC in your model you need to set the ESC so that it responds to your transmitter.

1. Switch on your transmitter and ensure the throttle control and throttle trim are in the neutral position.

2. Plug your ESC into your battery pack.

(The red & green LED's will flash for 2 seconds - This is the set-up window, if you press the button whilst the LED's are flashing you enter set-up, if you let the LED's flash for 2 seconds then stop, the ESC will operate with previously input set up values.)

**NOTE: If you have removed the factory fitted battery connector, (see warranty) ensure polarity is correct.**

3. Whilst the LED's are still flashing, press the set button, this will set your neutral position, the green LED will come on.
4. Push the throttle control to the full forward position and return to the neutral position, (This has set maximum forward speed point) the red LED will come on.
5. Pull the throttle control to the full reverse/astern position and return to the neutral position. (This has set the maximum brake/reverse/astern point) -Set up is complete!-

Failsafe - In failsafe mode the controller returns to the neutral position, this is indicated by a flashing red LED, failsafe is activated if there is loss of a good radio signal.

Battery type selection - The ESC is now compatible with LIPO cells, to switch between 'NiCAD/NiMH/Lead Acid' or 'LIPO' types you must press and hold the set button whilst switching the ESC on. After releasing the button the blue LED will toggle between on and off, for 'LIPO' release the button when the blue LED is on, for all other types, release the button when the blue LED is off.

Your ESC is now ready to use.