

# Conductor Bar

## 8 Bar | Side Contact

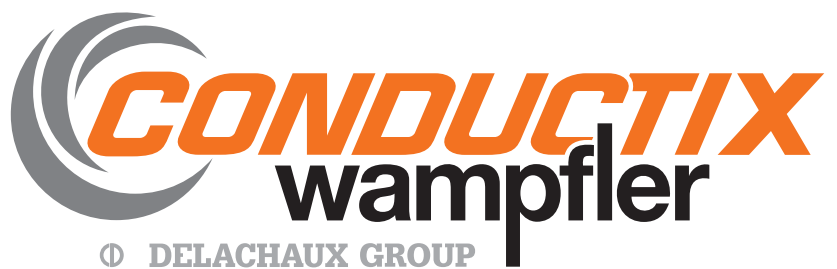

# Contents

Conductor Bar Summary Chart			3
Quick Quote Software			4
Comparison of 8 Bar and Safe-Lec 2			5
Quotations Data Sheet			6-7
Insul 8® 8 Bar and Side Contact Overview			8
<b>8 Bar</b>			<b>9-30</b>
Design Features			9
Typical 4-Bar Layout			10
Specifications			11
40 A Stainless Steel Conductors	12	90A, 110A Galvanized Steel Conductors	12
250A Stainless Clad Copper Conductors	13	250A Copper Steel Laminate Conductors	13
350A Rolled Copper Conductors	13	500A Solid Copper Conductors	13
Bar Covers, Connector Pins, and Joint Covers	14	Joint Parts and Tools	15
End Covers and Power Feeds	16	Expansion and Isolation Sections	17
Transfer Caps, Pickup Guides and Collector Brackets	18	Hanger and Anchor Clamps	19
Web and Flange Brackets Without Hangers	20	Web and Flange Brackets with Hangers	21
Universal Brackets	21-22	Collectors and Shoes	23-25
Curves and Slip Rings	25-26	Collector Dimensions	27
Hanger and Anchor Clamp Dimensions	28	Power Feed Dimensions	29
Pick-up Guide Dimensions	30	Crane Bridges and Runways	30
<b>Side Contact</b>			<b>31-43</b>
Design Features	31	Typical Mounting Arrangements	32
40A, 90A, 110A Conductors	33	250A, 350A Conductors	34
Expansion Sections	35	Connector Pins & Covers	36
Power Feed	37	Pick-up Guide	37
Hanger Brackets and Clamps	38	Collector Assemblies & Collector Parts	39-40
Collector Dimensions	41	Slip Rings and Curves	42
<b>Appendices</b>			
Appendix I Selection of Systems	43	Appendix II Voltage Drop Calculations	47
Appendix III Electrical Formulas & Conversions	48	Appendix IV Terms and Conditions	49
Other Conductor Rail Products	50	Other Conductix-Wampfler Products	51
Conductix-Wampfler Contact Information	52		

# Conductor Bar Summary Chart

## Conductor Bar Lines Manufactured in the USA

8-Bar and Side Contact are shown in catalog CAT1004. Hevi-Bar MD is shown in CAT1011.

	Safe-Lec 2	Hevi-Bar II	Hevi-Bar MD	8-Bar	Side Contact
<b>Common Applications</b>	Small to medium overhead cranes, moderate curves	Medium to large overhead cranes, higher speeds	Very large cranes, mill handling systems, and transit	Small to medium overhead cranes, tighter curves	Constrained spaces, slip ring applications, curves
<b>Bar Ampacity Selections</b>	100 125 160 200 250 315 400	500 700 1000 1500	2200 3800 4000 6000	40 90 110 250 350 500	40 90 110 250 350
<b>Max. Voltage</b>	600	600 <sup>1</sup>	600 <sup>1</sup>	600	600
<b>Max. Speed<sup>2</sup> ft/min (m/min.)</b>	1200 (365.7)	2000 (609.6)	2000 (609.6)	900 (274.3)	600 (182.8)
<b>Bar Spacing in. (mm)</b>	1.7 (43.2)	3.0 (76.2)	7.0 (177.8)	3.0 (76.2)	1.375 (34.9)
<b>Cover Temps</b> Low 160°F (71°C) Med. 250°F (121°C) High 400°F (204°C)	Low Med.	Low Med. High <small>(700A &amp; 1000A only)</small>	n/a	Low Med. High	Low Med.
<b>Outdoor Rated?</b>	Yes	Yes	Yes	Yes	No
<b>Dura-Coat Available?</b>	No	Yes	No	No	No
<b>Orientation (Collector Entry)</b>	Bottom/Side	Bottom/Side	Bottom/Side/Top	Bottom/Side	Side Only
<b>Min Bend Rad Low-Temp Cover in. (mm)</b>	60.0 (1524)	Consult Factory	n/a	18.0 (457) <sup>3</sup> 45.0 (1143) <sup>4</sup>	9.0 (228)
<b>Med-Temp. Cover in. (mm)</b>	60.0 (1524)	Consult Factory	n/a	57.0 (1447)	57.0 (1447)
<b>Heater Wire Available?</b>	Yes	500A only	n/a	No	No

<sup>1</sup> Can be configured for 5000 volts and more - contact Factory. <sup>2</sup> For faster speeds - contact Factory. <sup>3</sup> The "easy way" (bar profile vertical) <sup>4</sup> The "hard way" (horizontal)

### Conductix-Wampfler Germany - Conductor Rail Lines

Conductix-Wampfler Germany's high-performance conductor rails are stocked and available in the USA. Please contact our office at (+1) 800-521-4888 for more information. See Pg. 86 of this catalog for a brief overview of available series

**Don't see what you need? Give us a call. We offer hundreds of special designs and options!**

# “Quick Quote Web” Online System Quoting Program

Do you specify or purchase Conductor Bar, Cable Festoon Systems, or Push Button Pendants on a regular basis? If so, we recommend that you use our innovative **Quick Quote Web** online configuration tool. To access the program, all you need is a **Partners Site** login - see below.

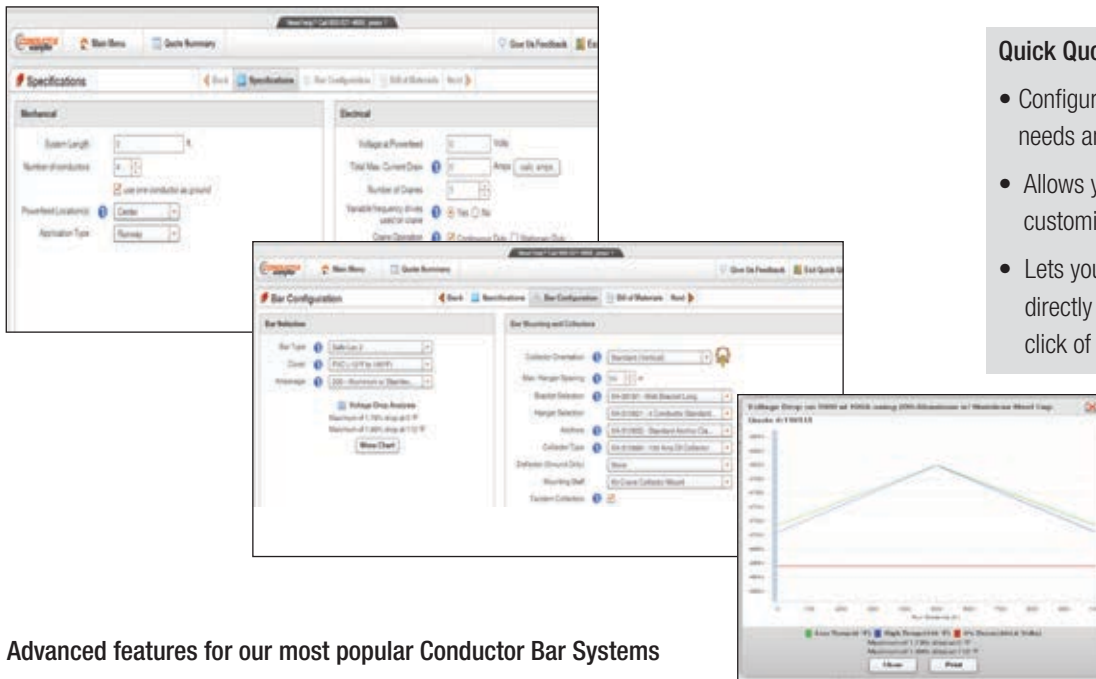

## Quick Quote Web:

- Configures systems based on your needs and generates a bill of material
- Allows you to create and save customized quotes for your customers
- Lets you turn your quote into an order, directly to Conductix-Wampfler at the click of a button.

## Advanced features for our most popular Conductor Bar Systems

- Calculates crane amp draw with one or more vehicles
- Automatically calculates and graphs voltage drop with single or multiple power feed locations
- Handles advanced bar and collector mounting configurations
- Provides conductor bar system schematic

## Advanced features for C-track and Square Bar Festoon Systems

- Handles most common festoon mounting configurations
- Lets you set-up cable package arrangements and trolley selection
- Handles factory pre-wiring and pre-assembly options for festoon systems

## Quick Quote Web allows you to add the appropriate Push Button Pendant

- Determines the type of pendant required based on your cable festoon system parameters
- Allows you to choose pre-configured pendants and related accessories, including pendant cable

Our **Quick Quote Web** program is available on our **Partners Site** at [www.conductix.us](http://www.conductix.us)

To access the program, you will need a Partners Site Login. Contact our Customer Service Team for details:

(+1) 800 521 4888 or (+1) 402 339 9300, Press 1.

Or by e-mail at [customerservice@conductix.com](mailto:customerservice@conductix.com)



8 Bar: El Tesoro Copper Mine, Chile

# Comparison of 8 Bar and Safe-Lec 2

The original Insul 8® 8 Bar is the best "figure 8" bar on the market. But if you are putting in a new installation, there are several reasons you should consider Safe-Lec 2 (CAT1003), the new standard in crane electrification.

## 8 Bar

- 10 ft (3.05 M) bar lengths; more splices required
- Hangers hold only one bar each

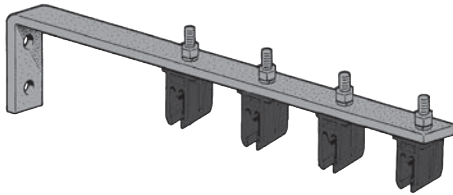

- Wires must be spliced to collector pigtails

- Pinned joints, no matter how good, are not as secure as bolts

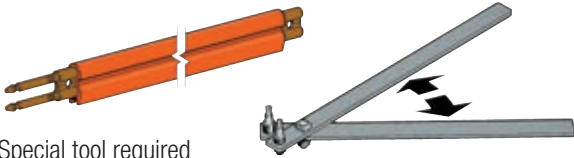

- Special tool required

- 8 Bar can go 300 ft before an expansion section is required (or 200 ft for copper bar)

- Brackets have round holes, so alignment must be more accurate
- Harder to make system alignment adjustments



- Shoe is guided by the plastic cover
- Accurate system alignment is much more critical



## Safe-Lec 2

### Quicker and Less Costly Installation

- 14.76 ft (4.50 M) bar lengths; fewer joints
- Multiple pole hangers; a "snap" to install

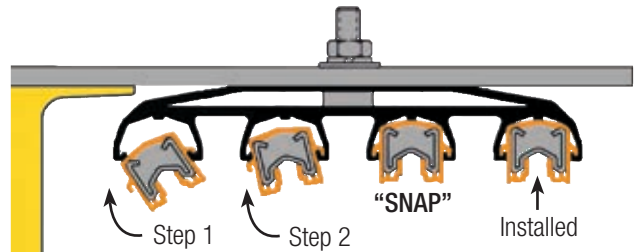

- Wires connect into lug integrated in the collector arm

### More Secure Bolted Splice Joint

- Bolted joints
- No special tools required
- No need for "joint keepers" or "joint repair kits", etc

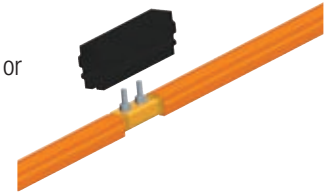

### Fewer Expansion Sections are Required

- Safe-Lec 2 can go further - 492 ft (150m) - before an expansion section is required

### Easier System Alignment

- Slotted brackets are available to reduce hole alignment problems
- System alignments are easy!

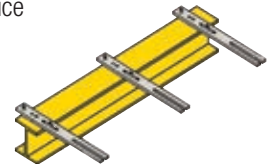

### Superior Collector Shoe Tracking

- Shoe is guided by the V-contact in the metal bar
- Collector arm articulates to accommodate mild system misalignments



# Conductor Bar Specification Data Sheet

Fax to: 800-780-8329 or 402-339-9627

E-mail to: info.us@conductix.com

Request Date	_____	Sales Person	_____
Company	_____	Name	_____
	_____	Title	_____
	_____	Phone	_____
	_____	Fax	_____
Company Type	_____	E-mail	_____

## APPLICATION

1. Application Type:  Runway  Bridge  Monorail  Other
2.  New Approved Installation?  Extended Existing?  Replacement?
3. System Length: \_\_\_\_\_  Feet  Meters
4. Total Number of Conductors: \_\_\_\_\_ Will one conductor be designated as a ground?  Yes  No

## ENVIRONMENTAL DATA

Describe the environment where the conductor system will be located:

1.  Indoors  Outdoors  Both Indoors and Outdoors  Outdoor & Ice
2. Ambient temperature range Min \_\_\_\_\_ Max \_\_\_\_\_ Degrees  Fahrenheit  Celsius
3. Will a heater wire need to be included?  Yes  No (if yes, contact factory)
4. Is there a source of corrosion present?  Yes  No **Refer to Appendix I page 43.**  
If yes, describe the corrosive: \_\_\_\_\_
5. Other environmental considerations (dust, etc.)? \_\_\_\_\_

## MECHANICAL DATA

1. Vehicle Speed \_\_\_\_\_  Feet/Min  M/Min Duty Cycle \_\_\_\_\_
2. Number of vehicles or trolleys \_\_\_\_\_ Crane Class (if applicable) \_\_\_\_\_  
**Refer to Appendix I page 43.**
3. Will Conductix-Wampfler be supplying bar mounting brackets?  Yes, Web Bracket  Yes, Flange Bracket  No, None
4. Does the system include any curves?  Yes  No (if yes, contact factory)
5. Other mechanical notes: \_\_\_\_\_

## ELECTRICAL SPECIFICATIONS

1. Number of power feeds \_\_\_\_\_
2. Location of power feeds (check all that apply):  Center  Multiple  End **Refer to Appendix I page 43.**  
 Advanced: Distance power feeds will be from end of system \_\_\_\_\_ (or attach diagram)
3. Number of power phases \_\_\_\_\_ Operating voltage \_\_\_\_\_ (volts)  AC  DC
4. Total current draw (sum of all vehicles ) \_\_\_\_\_ (Amps) Demand factor \_\_\_\_\_ (typically .9)
5. Operating Frequency \_\_\_\_\_ (Hz - USA is 60 Hz) (Refer to chart on page 7 for multiple cranes)

**Contact Conductix-Wampfler today to discuss your Conductor Bar application.**



# Conductor Bar Specification Data Sheet

## Sizing systems for multiple hoists, motors, and/or multiple cranes

**For a single crane:** Size the conductor bar to handle 100% of the current draw of the largest motor or group of motors, plus 50% of the combined current draw of the other motors on the vehicle.

**For multiple cranes or vehicles:** Determine the current draw for each crane/vehicle, using the method above. Sum all the current draws for each crane/vehicle, then multiply the sum by the appropriate demand factor:

# of Cranes/vehicles	Demand Factor
2	.95
3	.91
4	.87
5	.84
6	.81
7	.78



8 Bar: An excellent choice for tightly curved systems



# Insul 8<sup>®</sup> 8 Bar and Side Contact Overview

Conductix-Wampfler has designed and built state-of-the-art conductor bar systems for over 60 years. Our experienced engineering and sales people are recognized experts in the application of conductor bar in the most demanding applications.

Conductix-Wampfler USA was founded in 1944 as Insul-8 Corporation (San Carlos, CA). Insul-8 developed the first "Figure 8" conductor bar system, which became the standard method for electrifying overhead cranes. In 1991 the company moved its manufacturing facility to Harlan, Iowa.

With the merger of Conductix and Wampfler in 2007, **Conductix-Wampfler** is now the world leader in the design and manufacture of high-performance conductor bar systems for industry.

Our innovations include the "finger-safe", V-contact Safe-Lec 2 system, Hevi-Bar II with optional Dura-Coat corrosion protection, and Hevi-Bar MD for high-current mill applications.

Conductix-Wampfler 8 Bar and Side Contact systems are manufactured in the USA to provide unsurpassed service and quick delivery. Our plants are ISO9001-2008 certified and adhere to stringent quality standards.

We offer a full complement of other mobile electrification products to include Cable Festoon Systems, Cable Reels (spring and motor driven), Push-Button Pendants, Radio Remote Controls, and Crane Bumpers - see page 51 for details.

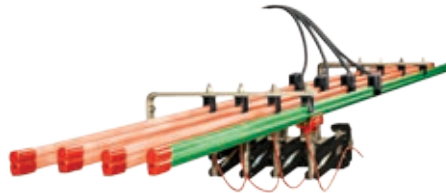

## 8 Bar

The first insulated conductor system for crane/monorail electrification. If you need 8 Bar, insist on the original! Many accessories available. Able to accommodate small bend radii for curved systems and slip rings. 40A, 90A, 110A, 250A, 350A, and 500A capacity bars.

UL / CSA Listed



## Side Contact

Similar in construction to 8 Bar, Side Contact is the appropriate system for constrained spaces and difficult installations. Side contact can accommodate very small bend radii for curved systems and slip rings. 40A, 90A, 110A, 250A, and 350A capacity bars.

UL / CSA Listed



## Safe-Lec 2 and Hevi-Bar II

For details on Safe-Lec 2 and Hevi Bar II conductor bar lines, please refer to catalog CAT1003 and CAT1006.

## 800 Series Conductor Rails

For details on 800 Series conductor bar products manufactured by Conductix-Wampfler, please refer to catalogs:

- KAT0811 811 Series
- KAT0812 812 Series
- KAT0813 813 Series
- KAT0815 815 Series
- KAT0831 831 Series, Multiline
- KAT0832 832 Series, EcoClick Line
- KAT0842 842 Series, Enclosed "Box Track"



Omaha, NE Plant

Harlan, IA Plant



# Insul 8<sup>®</sup> 8 Bar Design Features

Conductix-Wampfler "Insul 8<sup>®</sup> 8 Bar" was invented by Insul 8 Corporation over 60 years ago. This is the *original* "figure 8" conductor bar system! This innovative product was the first safe, insulated electrification solution for cranes, monorails, hoists, conveyors, and many other applications. Thousands of miles of 8 Bar are in use all around the world. There are many "copy cat" systems around. Don't settle for imitations; insist on the original 8 Bar system!

UL and CSA Listed

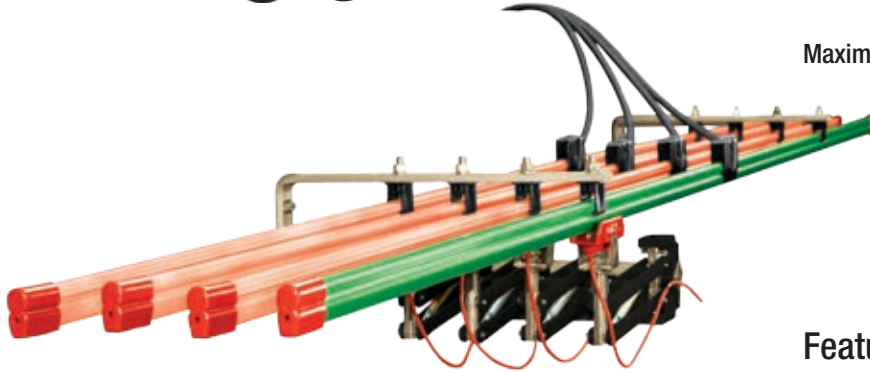

## Insul 8<sup>®</sup> 8 Bar is Ideal for:

- Small/Medium sized cranes
- Hoists
- Conveyors
- Tightly curved systems
- Monorails
- Other mobile power applications

**Current range:** 40A, 90A, 110A, 250A, 350A, 500A @ 600 volts max.

**Maximum Speed:** 900 ft/min (274 M/min)

## Features

- Designed and built in the USA under stringent ISO 9001:2008 standard
- In stock availability for quick shipment
- A large number of special options and adaptations developed over 60 years of usage to handle numerous industrial situations.
- The ability to be curved into a tighter radius than most other systems.
- Knurled joint pins for secure joints. Won't pull apart under normal conditions when properly installed.
- Backed by the best after-sale services in the industry.

## Basic 8 Bar Components

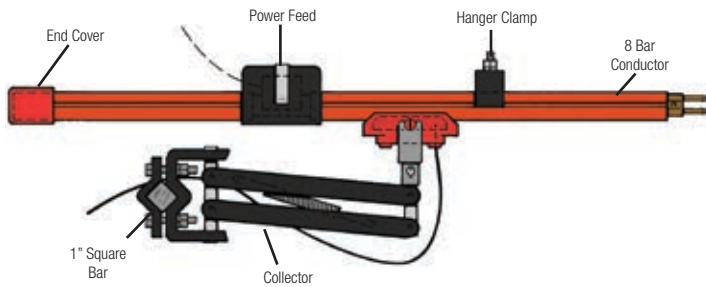

- Power Feed** Conducts the power source to the conductor bar
- Collector** Transfers power from the bar to the moving machine. Connects to a 1" mounting staff
- Hanger Clamp** Suspends the conductor bar from hanger bracket
- End Cover** Caps off the end of the conductor bar
- Hanger Bracket** Attaches to crane beam or other structure to support multiple hangers
- Anchor Clamp** Connects the bar to the structure and directs movement of the conductors during thermal expansion and contraction

## Installs Quickly and Easily

- Minimum number of basic parts
- Quick "pin-style" splice joints
- Bar snaps into mating hanger

## Many Options

- Stainless steel hardware
- Green bonding (ground) conductor covers
- Black "UV stable" outdoor covers
- Curved systems with low heat cover; can be curved to 18" minimum radius with the bar profile vertical (i.e. the "easy" way) or 45" the "hard way" (low heat cover).

Use our advanced "Quick Quote Web" configuration tool to specify 8 Bar - See page 4.

# Typical 4-Pole 8 Bar Layout

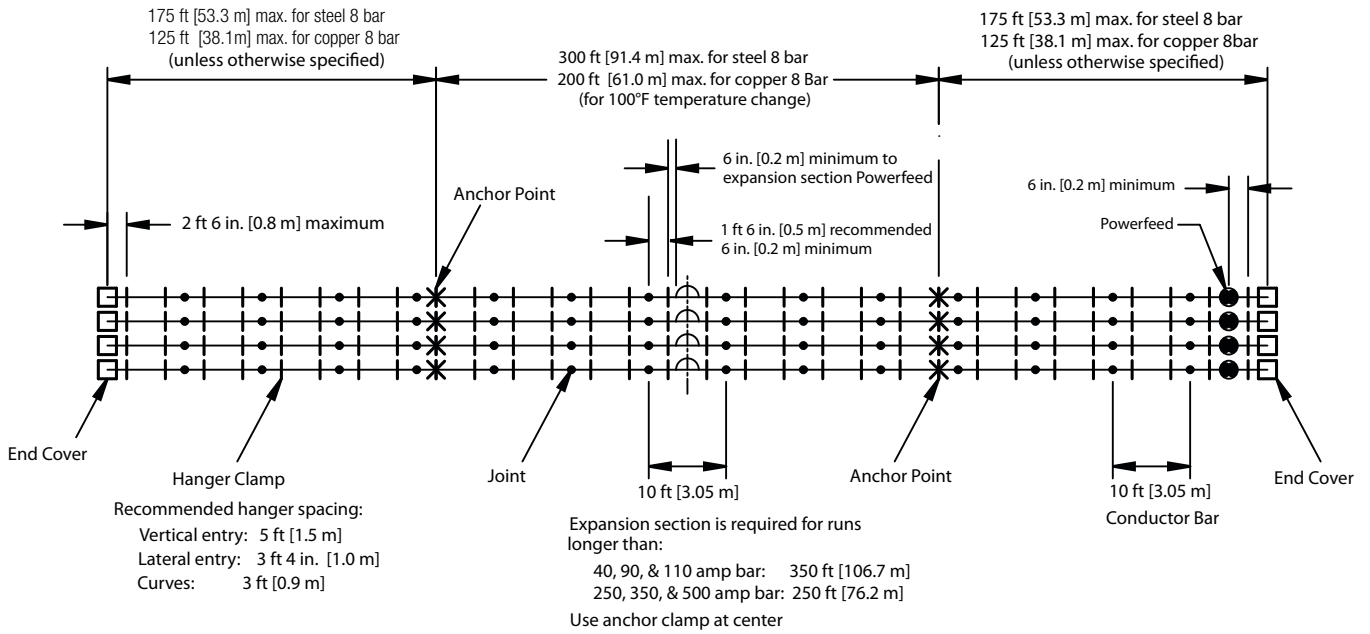

## 2-WAY STUB SWITCH

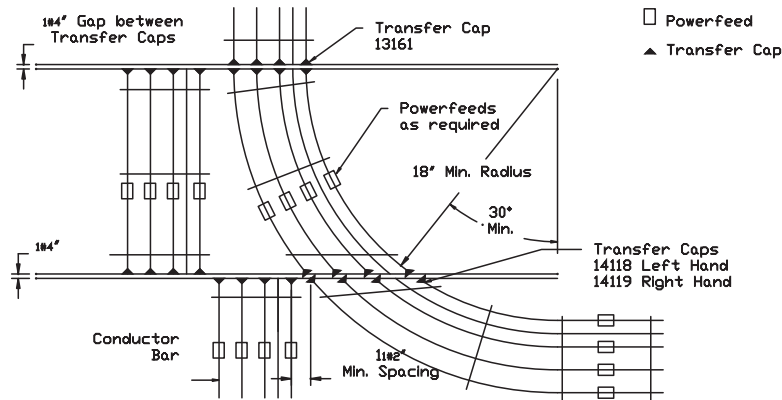

## BRIDGE CRANE INTERLOCK

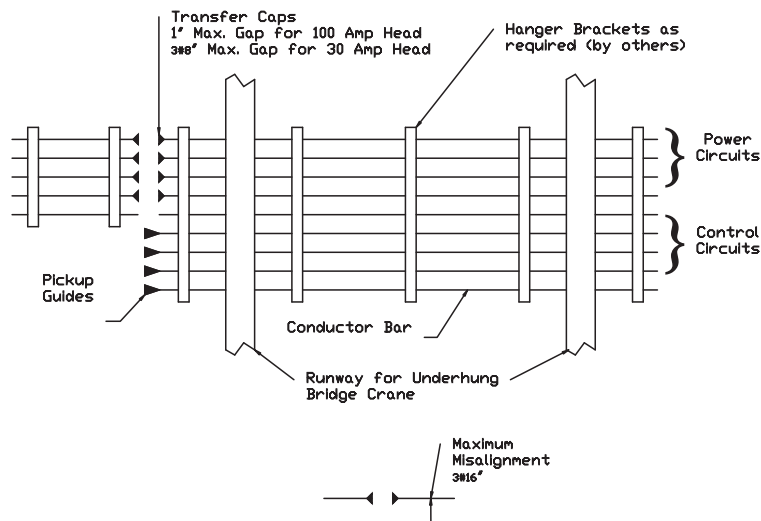

# 8 Bar Specifications

## Conductor Bar Information

Please use the Specification Data Sheets on pages 6-7 and the information in Appendices I through III at the back of this catalog to determine your conductor bar needs. Contact Conductix-Wampfler Sales if you have any questions about the suitability of this product to your application.

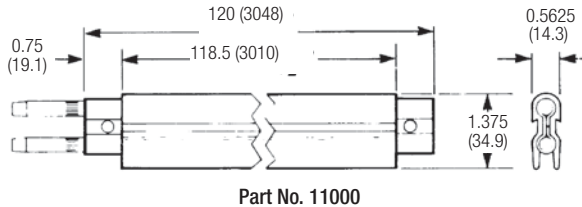

Roll formed of 1/16" (1.59 mm) material except laminates which are 1/32" (0.79 mm) copper, steel, or stainless steel, and the 90 A galvanized bar. The cross-section area is 188 mcm (95 mm<sup>2</sup>); except solid copper bar which is 313 mcm (158 mm<sup>2</sup>). The equivalent rectangle for all conductors is 1" x 1/4" (25.4 x 6.3 mm). Supports are required every 3 feet (0.91 M) for curves, 3 feet 4 inches (1.01 M) for lateral mount, and 5 feet (1.52 M) standard.

Assembled with Connector Pins and Cover							Micro-ohms per foot *			
Part No.							Max. Amps (cont. duty)	Resist. R (DC)	Reactance X (60 Hz, 3-Phase)	Impedance Z (60 Hz)
Material	Lgth ft (m)	w/PVC Cover	w/Med Heat Cover	w/High Heat Cover	Expansion Coefficient in./in./° F	Nominal Wt lb/ft (kg/M)				
Stainless Steel	10 (3.05)	<b>14299</b>	<b>24304</b>	<b>24307</b>	.000007	0.72 ( 0.0995)	40	2310	67	2311
Galvanized Steel	10 (3.05)	<b>22135</b>	<b>22141</b>	<b>22147</b>	.000007	0.46 (0.0636)	90	771	73	774
Galvanized Steel	10 (3.05)	<b>11000</b>	<b>11019</b>	<b>11038</b>	.000007	0.65 (0.0899)	110	500	67	505
Stainless Clad Copper Laminate	10 (3.05)	<b>11004</b>	<b>11023</b>	<b>11042</b>	.000009	0.65 (0.0899)	250	110	73	132
Copper Steel Laminate	10 (3.05)	<b>11008</b>	<b>11027</b>	<b>11046</b>	.000009	0.65 ( 0.0899)	250	110	77	127
Rolled Copper	10 (3.05)	<b>11012</b>	<b>11031</b>	<b>11050</b>	.000009	0.76 ( 0.1051)	350	55	66	86
Solid Copper	20 (6.10)	<b>11016</b>	<b>11035</b>	<b>11054</b>	.000009	1.16 ( 0.5262)	500	32	60	68

\* Example: 0.000060 ohms/ft. X values are calculated at 3 inch center-line spacing, adjusted for three conductors with multiplier 1:26 a nominal permeability  $\mu$  of 10-12 is used for the steel conductor calculations. For reference,  $X = m \frac{52.9 \log 10^3 \times 1.26 + 34.5}{1250}$ ,  $Z = \sqrt{R^2 + X^2}$

# 8 Bar Conductors

8 Bar conductor bars come with cover and connector pins installed. Bars are available in 40A, 90A, 110A, 250A, 350A, 500A capacities (@ 600 volts maximum). Expansion Sections, listed below, are required to compensation for thermal expansion; one every 350 feet (106.7 m) for 40A, 90A, and 100A systems or one every 250 feet (76.2 m) for 250A, 350A, and 500A systems.

Power Feeds are used to bring outside power to the conductor bar.

Factory installed covers are available in:

- **Rigid PVC:** -10° F to 160° F (- 23.3°C to 71.1°C)
- **Medium Heat:** - 25° F To 250° F (- 31.7°C to 121.1°C)
- **High Heat:** - 60° F To 400° F (-51.1°C to 204.2°C)

## Stainless Steel, 40A



Item	Rigid PVC Cover *		Med Heat Cover		High Heat Cover	
	Part No.	Wt lb (kg)	Part No.	Wt lb (kg)	Part No.	Wt lb (kg)
Conductor Bar, 10 ft (3.05 m)	<b>14299</b>	7.0 (3.18)	<b>24304</b>	6.6 (2.29)	<b>24307</b>	7.5 (3.40)
Conductor Bar, 5 ft (1.52 m)	<b>14823</b>	3.5 (1.59)	<b>24305</b>	3.3 (1.50)	<b>24308</b>	3.8 (1.72)
Expansion Section, 10 ft (3.05 m)	<b>24279</b>	7.5 (3.40)	<b>24306</b>	7.0 (3.18)	<b>24309</b>	8.2 (3.72)
Power Feed	<b>11091</b>	0.4 (0.18)	<b>11091</b>	0.4 (0.18)	<b>11122</b>	0.4 (0.18)
End Cover	<b>11088</b>	0.1 (0.05)	<b>11088</b>	0.1 (0.05)	<b>11633</b>	0.1 (0.05)

## Galvanized Steel, 90A



Item	Rigid PVC Cover *		Med Heat Cover		High Heat Cover	
	Part No.	Wt lb (kg)	Part No.	Wt lb (kg)	Part No.	Wt lb (kg)
Conductor Bar, 10 ft (3.05 m)	<b>22135</b>	4.4 (2.00)	<b>22141</b>	4.1 (1.86)	<b>22147</b>	4.9 (2.22)
Conductor Bar, 5 ft (1.52 m)	<b>22136</b>	2.2 (1.00)	<b>22142</b>	2.1 (0.95)	<b>22148</b>	2.5 (1.14)
Expansion Section, 10 ft (3.05 m)	<b>22140</b>	6.7 (3.31)	<b>22146</b>	6.3 (2.86)	<b>22152</b>	7.4 (3.36)
Power Feed	<b>11091</b>	0.4 (0.18)	<b>11091</b>	0.4 (0.18)	<b>11122</b>	0.4 (0.18)
End Cover	<b>22070</b>	0.1 (0.05)	<b>22070</b>	0.1 (0.05)	<b>11633</b>	0.1 (0.05)

## Galvanized Steel, 110A



Item	Rigid PVC Cover *		Med Heat Cover		High Heat Cover	
	Part No.	Wt lb (kg)	Part No.	Wt lb (kg)	Part No.	Wt lb (kg)
Conductor Bar, 10 ft (3.05 m)	<b>11000</b>	4.4 (2.00)	<b>11019</b>	4.1 (1.86)	<b>11038</b>	4.9 (2.22)
Conductor Bar, 5 ft (1.52 m)	<b>11001</b>	2.2 (1.00)	<b>11020</b>	2.1 (0.95)	<b>11039</b>	2.5 (1.13)
Expansion Section, 10 ft (3.05 m)	<b>11057</b>	6.7 (3.31)	<b>11064</b>	6.3 (2.86)	<b>11070</b>	7.4 (3.36)
Power Feed	<b>11091</b>	0.4 (0.18)	<b>11091</b>	0.4 (0.18)	<b>11122</b>	0.4 (0.18)
End Cover	<b>11088</b>	0.1 (0.05)	<b>11088</b>	0.1 (0.05)	<b>11633</b>	0.1 (0.05)

\* For Conductor Bar or Expansion Section with green PVC cover, add "G" to part no.

\* For Conductor Bar or Expansion Section with black UV resistant PVC, add "B" to the part no.

# 8 Bar Conductors

## Stainless Clad Copper, 250A

Requires a Joint Keeper (page 15) with each conductor bar - order separately



Item	Rigid PVC Cover *		Med Heat Cover		High Heat Cover	
	Part No.	Wt lb (kg)	Part No.	Wt lb (kg)	Part No.	Wt lb (kg)
Conductor Bar, 10 ft (3.05 m)	<b>11004</b>	6.6 (2.99)	<b>11023</b>	6.2 (2.81)	<b>11042</b>	7.1 (3.22)
Conductor Bar, 5 ft (1.52 m)	<b>11005</b>	3.3 (1.47)	<b>11024</b>	3.1 (1.41)	<b>11043</b>	3.6 (1.63)
Expansion Section, 10 ft (3.05 m)	<b>11059</b>	8.5 (3.86)	<b>11065</b>	8.0 (3.63)	<b>11071</b>	9.2 (4.17)
Power Feed	<b>11092</b>	0.7 (0.32)	<b>11093</b>	0.7 (0.32)	<b>11093</b>	0.7 (0.32)
End Cover	<b>11088</b>	0.1 (0.05)	<b>11088</b>	0.1 (0.05)	<b>11633</b>	0.4 (0.18)

## Copper Steel Laminate, 250A

Requires a Joint Keeper (page 15) with each conductor bar - order separately



Item	Rigid PVC Cover *		Medium Heat cover		High Heat Cover	
	Part No.	Wt lb (kg)	Part No.	Wt lb (kg)	Part No.	Wt lb (kg)
Conductor Bar, 10 ft (3.05 m)	<b>11008</b>	6.2 (2.81)	<b>11027</b>	5.8 (2.63)	<b>11046</b>	6.7 (3.04)
Conductor Bar, 5 ft (1.52 m)	<b>11009</b>	3.1 (1.41)	<b>11028</b>	2.9 (1.32)	<b>11047</b>	3.4 (1.54)
Expansion Section, 10 ft (3.05 m)	<b>11060</b>	10.0 (4.54)	<b>11066</b>	9.4 (4.26)	<b>11072</b>	10.8 (4.90)
Power Feed	<b>11092</b>	0.7 (0.32)	<b>11093</b>	0.7 (0.32)	<b>11093</b>	0.7 (0.32)
End Cover	<b>11088</b>	0.1 (0.05)	<b>11088</b>	0.1 (0.05)	<b>11633</b>	0.4 (0.18)

## Rolled Copper, 350A

Requires a Joint Keeper (page 15) with each conductor bar - order separately



Item	Rigid PVC Cover *		Medium Heat Cover		High Heat Cover	
	Part No.	Wt lb (kg)	Part No.	Wt lb (kg)	Part No.	Wt lb (kg)
Conductor Bar, 10 ft (3.05 m)	<b>11012</b>	7.0 (3.18)	<b>11031</b>	6.6 (2.99)	<b>11050</b>	7.5 (3.40)
Conductor Bar, 5 ft (1.52 m)	<b>11013</b>	3.5 (1.59)	<b>11032</b>	3.3 (1.50)	<b>11051</b>	3.8 (1.72)
Expansion Section, 10 ft (3.05 m)	<b>11062</b>	11.0 (4.99)	<b>11068</b>	11.0 (4.99)	<b>11074</b>	11.8 (5.35)
Power Feed	<b>11094</b>	0.7 (0.32)	<b>11094</b>	0.7 (0.32)	<b>11094</b>	0.7 (0.32)
End Cover	<b>11088</b>	0.1 (0.05)	<b>11088</b>	0.1 (0.05)	<b>11633</b>	0.4 (0.18)

## Solid Copper, 500A

500 amp solid copper bar requires copper connector clamp rather than connector pins, purchased separately see page 15.



Item	Rigid PVC Cover *		Medium Heat Cover		High Heat Cover	
	Part No.	Wt lb (kg)	Part No.	Wt lb (kg)	Part No.	Wt lb (kg)
Conductor Bar, 20 ft (6.10 m)	<b>11016</b>	23.6 (10.71)	<b>11035</b>	22.1 (10.02)	<b>11054</b>	24.6 (11.16)
Conductor Bar, 10 ft (3.05 m)	<b>11017</b>	11.8 (5.35)	<b>11036</b>	11.0 (4.99)	<b>11055</b>	12.3 (5.58)
Expansion Section, 10 ft (3.05 m)	<b>11063</b>	18.5 (3.39)	<b>11069</b>	17.3 (7.85)	<b>11075</b>	20.0 (9.07)
Power Feed	<b>11094</b>	2.6 (1.18)	<b>11094</b>	2.6 (1.18)	<b>11094</b>	2.6 (1.18)
End Cover	<b>12171</b>	0.2 (0.09)	<b>11633</b>	0.2 (0.09)	<b>11633</b>	0.4 (0.18)

\* For Conductor Bar or Expansion Section with green PVC cover, add "G" to part no.

\* For Conductor Bar or Expansion Section with black UV resistant PVC, add "B" to the part no.



# 8 Bar Replacement Covers, Connectors, & Joint Covers

## Replacement 8 Bar Covers

Meets all requirements for plastic electrical insulation and may be used indoors or outdoors. Covers are included with the conductors listed on pages 12-13.

Replacement length is 9 ft to 10.5 ft. (2.74 M to 3.20 M)



Material	Color	Temp-Rating	Part No.	Wt lb (kg)
Rigid PVC	Orange	-10° F to 160° F	<b>11114</b>	1.2 (0.54)
Rigid PVC	Green	-10° F to 160° F	<b>11114G</b>	1.2 (0.54)
UV Resistant PVC	Black	-10° F to 160° F	<b>11114B</b>	1.2 (0.54)
Medium Heat Lexan	Red	-25° F to 250° F	<b>11115</b>	0.8 (0.36)
High Heat Polyester	Dark Orange	-60° F to 400° F	<b>11116</b>	1.7 (0.77)

## Replacement Connector Pins

Used to connect two bar sections together. For quick and easy installation. Supplied with conductors listed on pages 12-13. Two required per connection.



21914



11120

Pin Used With:	Material	Pin Lgth (in.)	Part No.
Stainless steel 40A 8 Bar	Stainless steel	2.50	<b>24196</b>
Galvanized steel 90A 8 Bar	Zinc plated steel	3.25	<b>21914</b>
Galvanized steel 110A 8 Bar	Zinc plated Steel	2.50	<b>11120</b>
Rolled copper and laminated 8 Bar	Copper	2.50	<b>11121</b>
Transition Pin: To join 90 to 110A 8 Bar	Zinc plated steel	2.94	<b>22885</b>

## Joint Covers

Insulated protective covers for conductor bar joining parts. Required when ordering Conductor Bars from pages 12-13.



Used with:	Part No.	Wt lb (kg)
40A to 350A Rigid PVC Cover (Black)	<b>13601</b>	0.1 (0.05)
40A to 350A Medium Heat Cover	<b>13600</b>	0.1 (0.05)
40A to 350A High Heat Cover	<b>11123</b>	0.4 (0.18)

# 8 Bar Joint Parts & Tools

## Copper Connector Clamp and Case



11117 (Shown with only half of the cover)

To connect 500A solid copper conductor together. For all cover types.

Description	Part No.	Wt lb (kg)
Complete Assembly for Solid Copper 8 Bar	<b>11117</b>	1.5 (0.68)

## Joint Keeper



Required to secure and stabilize joints for all rolled copper or laminated copper Conductor Bar from page 13.

Used With:	Part No.	Wt lb (kg)
Rolled or laminated copper 8 Bar, 250A and 350A	<b>11125</b>	0.01 (0.004)

## Joint Repair Kit



24632 (Shown with only half cover)

To repair joints of damaged conductor bar.

Used For:	Part No.	Wt lb (kg)
40A to 350A formed 8 Bar	<b>24632</b>	0.7 (0.32)
High Heat Systems	<b>51666</b>	0.7 (0.32)

## Connector Pin Tool



Inserts into pre-punched holes of the conductor bar to pull conductor sections together securely. Supplied with the appropriate system at a nominal charge.

Used with:	Part No.	Wt lb (kg)
40A to 350A 8 Bar Conductors	<b>11134</b>	2.3 ( 1.04)

# 8 Bar End Covers & Power Feeds

## End Cover

For covering the exposed ends of 8 Bar Conductors.



11088

Used With 8 Bar Conductors:	Max. Temp. °F ( °C)	Part No.	Wt lb (kg)
40A, 110A thru 350A	300 (149)	<b>11088</b>	0.03 ( 0.02)
90A	400 (204)	<b>22070</b>	0.03 ( 0.02)
110A thru 350A	400 (204)	<b>11633</b>	0.03 ( 0.02)
500A Solid Copper	160 (71)	<b>12171</b>	0.40 (0.02)
500A Solid Copper w/ Stainless Steel Hardware	160 (71)	<b>27102</b>	0.40 ( 0.02)

## Power Feeds

Provides attachment of incoming power to the conductor rails. Fully insulated, simple clamp design for easy installation anywhere on the system.



11091

Current Cap.	Clamp Matl	Case Matl	Max. Temp °F ( °C)	Part No.	Wt lb (kg)
90 or 110	Steel	Rigid PVC	160 (71)	<b>11091</b>	0.4 ( 0.18 )
90 or 110	Steel	Polyester	400 (204)	<b>11122</b>	0.4(0.18)
250	Copper	Rigid PVC	160 (71)	<b>11092</b>	0.7 ( 0.32)
250	Copper	Polyester	400 (204)	<b>11093</b>	0.7 ( 0.32 )
500	Copper	Polyester	400 (204)	<b>11094</b>	2.60 (1.19)
250	Copper Clamp w/Stainless Steel Hardware	Rigid PVC	160 (71)	<b>27104</b>	0.7 ( 0.32 )
500	Copper Clamp w/Stainless Steel Hardware	Polyester	400 (204.2)	<b>27106</b>	2.60 (1.19)

## Power Feed Parts/Accessories

Description	Part No.	Wt lb (kg)
Case & clip only. PVC 90/110, 250A	<b>11131</b>	0.2 ( 0.09)
Case & clip only. High heat. 90/110, 250A	<b>11132</b>	0.3 ( 0.14)
Case only. High heat 500A	<b>11133</b>	1.0 ( 0.45)
Power Feed Clamp only. For Galvanized Steel, 90/110A	<b>11128</b>	0.1 ( 0.04)
Power Feed Clamp only. For Copper, 250A	<b>11129</b>	0.4 (0.18)

# 8 Bar Expansions & Isolation Sections

## Expansion Section

Required every 300 feet (94.1 m) for steel conductors or every 200 feet (61.0 m) for copper conductors to compensate for thermal expansion. Power feeds and flexible jumpers are factory installed to meet electrical and mechanical requirements of your system.

**Note: Part numbers are located in the Conductor Bar tables - See pages 12-13.**



## Isolation Section

Conductor isolation sections are used to electrically isolate control circuits, maintenance bays, etc. The kit includes 11127 Guide Assembly, PVC Cover, and Isolation Section for 40A to 350A (not including 90A). Contact our factory for proper selection.



Part No.	Wt lb (kg)
21841	2.3 (1.04)

## Isolation Section Parts

Components used for in-field modification.

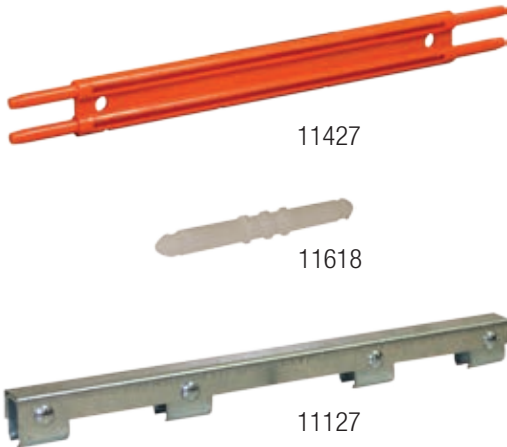

Description	Part No.	Wt lb (kg)
Molded plastic insulating piece; only for 21841	11427	0.3 (0.14)
Molded plastic 1" (25.4 mm) isolating pin. For 40-350A except for 90A; Two required per location.	11615	0.03 (0.01)
Molded plastic, 1" (25.4 mm) isolating pin. For 90A only. Two required per location.	11618	0.03 (0.01)
Galvanized Steel Guide Assembly. Provides rigid support at isolation areas.	11127	1.5 (0.68)

# 8 Bar Transfer Caps, Pickup Guides, Collector Brackets

## Transfer Caps



Used in switches and interlocks to accomplish smooth collector transfer.

Item Description	Part No.	Wt lb (kg)
End Transfer Cap for 90A bar.	<b>22070</b>	0.03 (0.01)
Left Transfer Cap for 90A bar.	<b>22395</b>	0.03 (0.01)
Right Transfer Cap for 90A bar.	<b>22396</b>	0.03 (0.01)
End Transfer Cap for 40-350A bar	<b>13161</b>	0.03 (0.01)
Left-hand Cap for 40-350A bar	<b>14118</b>	0.03 (0.01)
Right-hand Cap for 40-350A bar	<b>14119</b>	0.03 (0.01)

## Pick-Up Guides



The Pick-up Guide allows the collector to leave the conductor and re-track upon return. Requires use of "Self-Centering" J-Head Collectors, see pages 23-24. Contact factory for selection.

Used:	Part No.	Wt lb (kg)
Indoors, for 3" bar spacing	<b>13142</b>	1.75 (0.79)
Indoors, for 4" bar spacing	<b>11089</b>	1.75 (0.79)
Outdoors, for 3" bar spacing	<b>13143</b>	2.00 (0.91)
Outdoors, for 4" bar spacing	<b>11090</b>	2.00 (0.91)

## Collector Brackets

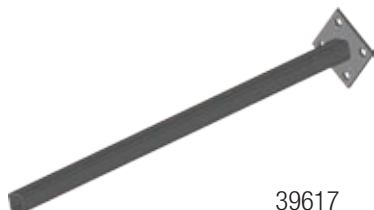

For mounting collectors to the moving vehicle. Applicable for all 8 Bar and Saf-T-Bar Series C Collectors. See pages 23 and 24 for Collector Assembly descriptions.

TYPE	Type	Post Size in. (mm)	Part No.	Wt lb (kg)
Single post	Plated steel	1.00 (25)	<b>39617</b>	1.77 (0.80)
Single post	Stainless steel	1.00 (25)	<b>50142</b>	1.77 (0.80)



# 8 Bar Hanger and Anchor Clamps

## Polycarbonate Snap-in Hanger Clamps



Hanger Clamps are designed to grip 8 Bar Conductors for stable support. Clamps are required every 5 foot (1.52 M) standard. These Polycarbonate Snap-in Hanger Clamps are recommended for standard mount only; not recommended for curves or lateral mount.

Type	Hardware	Part No.	Wt lb (kg)
Without Insulator	Zinc Plated	<b>22800</b>	0.3 (0.14)
Without Insulator	Stainless Steel	<b>23370</b>	0.3 (0.14)
With Insulator	Zinc Plated	<b>24405</b>	0.5 (0.23)
With Insulator	Stainless Steel	<b>28122</b>	0.5 (0.23)

## Steel Snap-in Hanger Clamp



The spring-steel Hanger Clamps are designed to grip 8 Bar Conductors for stable support.

Clamps are required every 5 foot (1.52 M) standard. Steel Snap-in Hanger Clamps are recommended for standard mounting; not recommended for curves or lateral mount.

Type	Part No.	Wt lb (kg)
Without Insulator	<b>21600</b>	0.2 (0.09)
With Insulator	<b>22000</b>	0.4 (0.18)

## Cross-Bolt Hanger Clamp



Cross-Bolt Hanger Clamps are designed to lock to 8 Bar Conductors for stable support.

Hangers are required every 5' for vertical entry, 3' for curved systems and every 3' 4" for lateral entry. Cross-Bolt Hanger Clamps are recommended for standard mounting, lateral mounting, and curved systems.

Type	Material	Part No.	Wt lb (kg)
Without Insulator	Plated Steel	<b>11076</b>	0.3 (0.14)
Without Insulator	Stainless Steel	<b>11078</b>	0.3 (0.14)
With Insulator	Plated Steel	<b>11082</b>	0.5 (0.23)
With Insulator	Stainless Steel	<b>11084</b>	0.5 (0.23)

## Anchor Clamp



For standard mount, not recommended for curves or lateral mount.

Type	Material	Part No.	Wt lb (kg)
Without Insulator	Plated Steel	<b>21833</b>	0.3 (0.14)
Without Insulator	Stainless Steel	<b>28123</b>	0.3 (0.14)
With Insulator	Plated Steel	<b>21982</b>	0.5 (0.23)
With Insulator	Stainless Steel	<b>28124</b>	0.5 (0.23)

# 8 Bar Standard Brackets - Without Hangers

## Web Bracket



22014

For top running, web-mounted, bottom entry systems. Zinc plated steel. See page 19 for hangers.

Distance to First Hole:	Part No.	Wt lb (kg)
6.0 (152)	<b>22014</b>	2.4 (1.09)
9.0 (229); with three more holes - At 12.0 (305), 15 (381), and 18 (457)	<b>29876</b>	4.5 (2.04)

## Flange Mount Brackets



27762

For bottom entry monorail and under-hung systems, flange-mounted. Zinc plated steel. See page 19 for hangers.

Type	Part No.	Wt lb (kg)
For 2 hangers each side	<b>27762</b>	2.5 (1.13)
For 4 hangers on one side	<b>27767</b>	2.5 (1.13)

# 8 Bar Standard Brackets - With Hangers

## Brackets w/Pre-Assembled Hanger Clamps

The following brackets come with hanger clamps on 3" centers, brackets are zinc plated steel. **Hanger Clamp styles are described on page 19.**

### With Polycarbonate Snap-In Hanger Clamps

Description	Without Insulators		With Insulators	
	Part No.	Wt lb (kg)	Part No.	Wt lb (kg)
Web type 6.0" (152)	<b>28829</b>	2.0 (0.91)	<b>51004</b>	2.4 (1.09)
Web type 9.0" (229)	<b>34189</b>	3.1 (1.40)	<b>50314</b>	3.5 (1.59)
Flange type, 2 hangers each side	<b>51864</b>	2.6 (1.18)	<b>51865</b>	3.1 (1.41)
Flange type, 4 hangers on one side	<b>51870</b>	2.6 (1.18)	<b>51871</b>	3.1 (1.41)

### Steel Snap-In Hanger Clamps

Description	Without Insulators		With Insulators	
	Part No.	Wt lb (kg)	Part No.	Wt lb (kg)
Web type 6.0" (152)	<b>30281</b>	1.6 (0.73)	<b>51005</b>	2.0 (0.91)
Web type 9.0" (229)	<b>50313</b>	2.7 (1.23)	<b>50315</b>	3.1 (1.41)
Flange type, 2 hangers each side	<b>51866</b>	2.1 (0.95)	<b>51867</b>	2.5 (1.11)
Flange type, 4 hangers on one side	<b>51872</b>	2.1 (0.95)	<b>51873</b>	2.5 (1.11)



Web Bracket with hangers installed (# 34189 shown)

### Cross-Bolt Hanger Clamps

Description	Without Insulators		With Insulators	
	Part No.	Wt lb (kg)	Part No.	Wt lb (kg)
Web type 6.0" (152)	<b>31762</b>	2.0 (0.91)	<b>29534</b>	2.3 (1.04)
Web type 9.0" (229)	<b>50312</b>	3.1 (1.41)	<b>50316</b>	3.5 (1.59)
Flange type, 2 hangers each side	<b>51868</b>	2.5 (1.11)	<b>51869</b>	2.9 (1.32)
Flange type, 4 hangers on one side	<b>51874</b>	2.5 (1.11)	<b>51875</b>	2.9 (1.32)



Flange Bracket with hangers installed (# 51864 shown)

# 8 Bar Universal Brackets

You can order pre-assembled brackets with your choice of hangers on page 21. Or, if these hanger locations don't work for the application, the "Universal Brackets" shown below should address most special applications. Holes are drilled on 1.0 inch (25.4 mm) centers.

Type	Length	Part No.	Wt lb (kg)
Web Bracket, Short	11.5 (29)	<b>31409</b>	1.0 (0.45)
Web Bracket, Long	15.5 (39)	<b>31407</b>	1.3 (0.59)
Flange Bracket	18.0 (46)	<b>31408</b>	1.2 (0.54)
Flange Bracket with Beam Clips	18.0 (46)	<b>31418</b>	1.6 (0.73)
Flange Bracket with Beam Clips	24.0 (61)	<b>31911</b>	2.0 (0.91)

## Web Bracket - Short (31409)

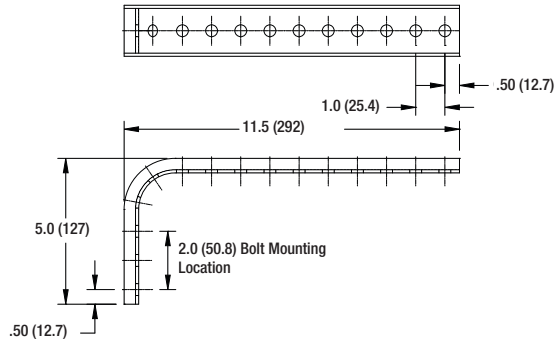

## Web Bracket - Long (31407)

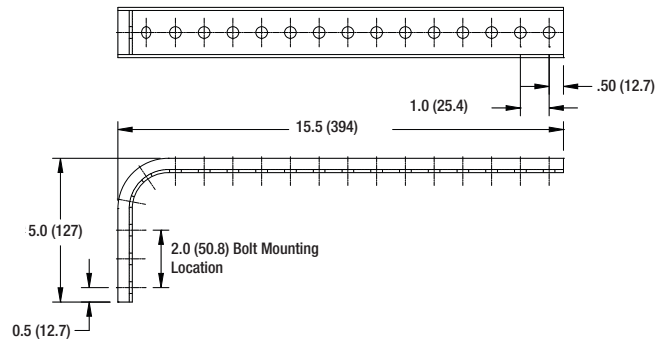

## Flange Bracket (31408)

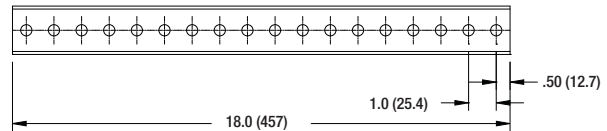

## Flange Bracket with Clips (31418)

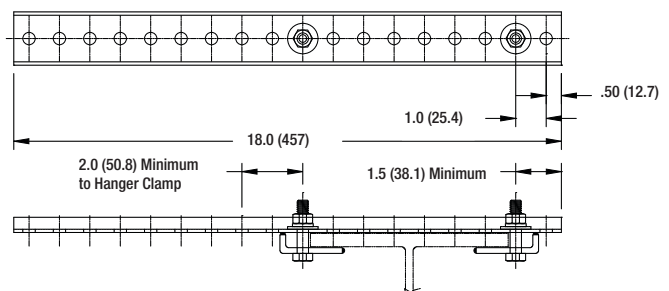

# 8 Bar Universal Brackets with Pre-assembled Hangers

## Ordering Instructions:

- 1) Choose the part number of the desired bracket from the styles shown below.
- 2) Referring to the drawings below, choose the hole number locations at which hangers are to be assembled observing the minimum bar spacing table below:

### Recommended Minimum Conductor Bar Spacing

	Indoor, inch (mm)	Outdoor, inch (mm)
8 Bar (bottom entry)	2.0 (50.8)	3.0 (76.2)
Side Contact (Lateral Mount)	3.0 (76.2)	Not for outside use

For less than 2.0" (50.8 mm) spacing, contact factory

- 3) From page 19, select desired hanger type by part number.

**Example: 10 Universal Brackets with four polycarbonate snap-in hangers on each:**

Qty	Part No. (hole numbers where hangers are to be mounted)	Description
10	31407 (1, 3, 5, 7)	Web Bracket, Long (from below)
40	22800	Polycarbonate Snap Hanger (from page 19)

**Note: When the order is received, a unique part number will be created for the requested bracket and hanger combination.**

## Bracket Hole Position Numbers

Holes start 0.5" from the end of the bracket and are 1" on-center.

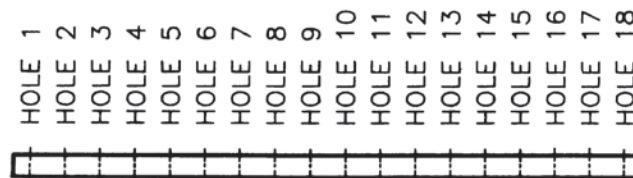
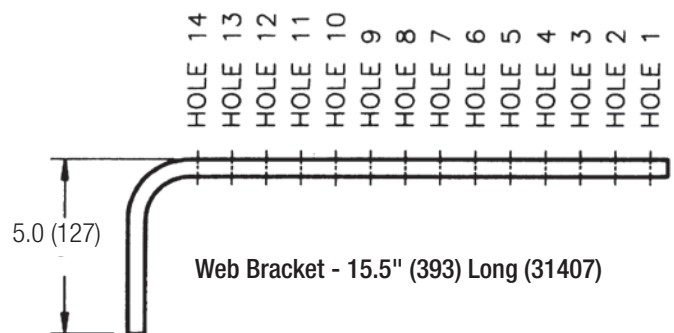
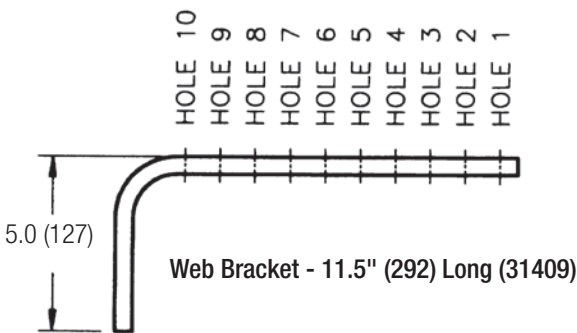

Flange Bracket with Beam Clips - 18" (457) Long (31418)

# 8 Bar Collector Assemblies

Sliding contact Collector Assemblies are offered in either single shoe or tandem shoe configurations. Current capacities range from 30A to 200A depending on the model. The shoes are supported by insulated holders on articulating, spring-loaded collector arms. Most collector arms are made from **Grivory GV-5**, a high-strength fiberglass-filled polymer material that is stronger and less porous than aluminum. Wear on the collector assembly is confined to easily replaceable contact shoes.

## 30A and 60A J-Head, C-Base Type



For systems up to 600 volts with straight runs and curves to 18" minimum radius. Assemblies have 19" pigtails (not shown in the illustration). Choose standard bottom entry or lateral-mount versions.

Replacement shoe for these collectors is Part No. [13136](#) - see page 25.

Type	Mounting	Cap.	Part No.	Wt lb (kg)
Single	Bottom Entry	30A	<b>13128</b>	2.5 (1.13)
Tandem	Bottom Entry	60A	<b>13082</b>	4.7 (2.13)
Single	Lateral-Mount	30A	<b>13129</b>	2.5 (1.13)
Tandem	Lateral-Mount	60A	<b>13083</b>	4.7 (2.13)

## 30A and 60A Self-Centering J-Head, C-Base Type

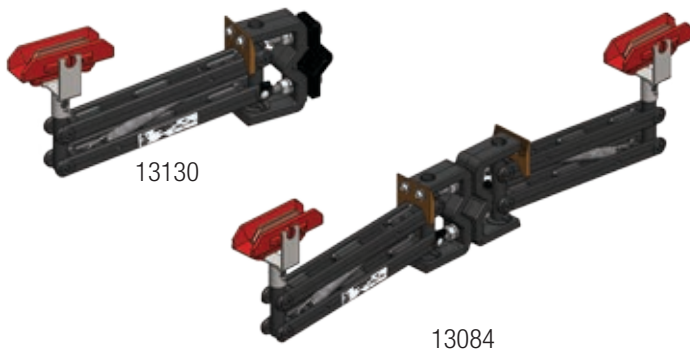

The "Self-Centering" versions below are used with Pick-up Guides, see page 18. These are for bottom entry mounting and have 19" pigtails (not shown in the illustration).

Replacement shoe for these collectors is Part No. [13136](#), see page 25.

Type	Cap.	Part No.	Wt lb (kg)
Self-Centering Single	30A	<b>13130</b>	2.6 (1.18)
Self-Centering Tandem	60A	<b>13084</b>	4.9 (2.22)

## 30A J-Head, H-Base Type

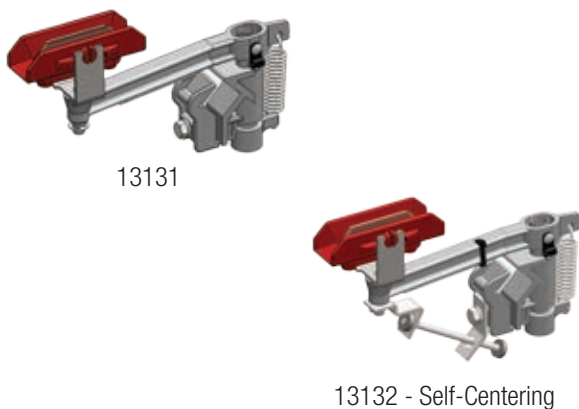

For systems up to 600 volts with straight runs and curves to 18" minimum radius. Assemblies have 15" pigtails (not shown in the illustration). Choose standard bottom entry or lateral-mount versions.

The "Self-Centering" version is used with Pick-up Guides, see page 18.

Replacement shoe for these collector is Part No. [13136](#), see page 25.

Type	Cap.	Part No.	Wt lb (kg)
Single	30A	<b>13131</b>	1.4 (0.64)
Self-Centering Single	30A	<b>13132</b>	1.7 (0.77)
Lateral-Mount Single	30A	<b>13133</b>	1.4 (0.64)



# 8 Bar Collector Assemblies

## 100A and 200A J-Head, C-Base Type

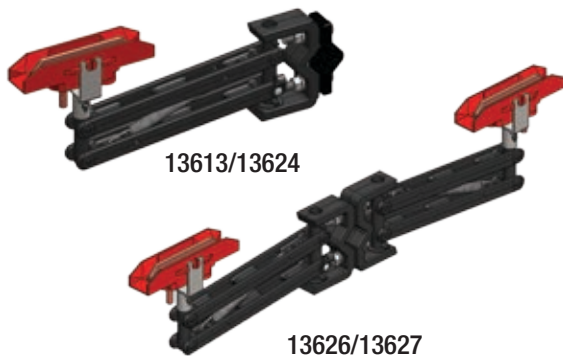

For straight system runs of 600V or less. Assemblies have 21" pigtails (not shown in the illustration). Choose standard "bottom entry" or lateral-mount versions.

Replacement shoe for this collector is Part No. [11157](#) - see page 25.

Type	Mounting	Cap.	Part No.	Wt lb (kg)
Single	Bottom Entry	100A	<b>13613</b>	3.1 (1.41)
Tandem	Bottom Entry	200A	<b>13626</b>	5.8 ( 6.23)
Single	Lateral-Mount	100A	<b>13624</b>	3.1 (1.41)
Tandem	Lateral-Mount	200A	<b>13627</b>	5.8 ( 6.23)

## 100A and 200A J-Head, C-Base Type Self-Centering

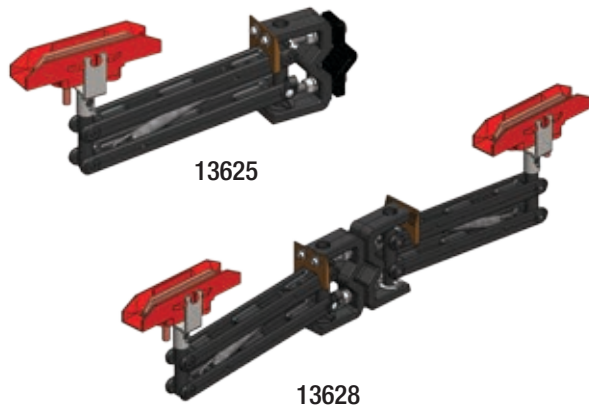

The "Self-Centering" versions are used with Pick-up Guides - See page 18. For straight system runs of 600V or less. These are for bottom entry mounting and have 21" pigtails (not shown in the illustration).

Replacement shoe for this collector is Part No. [11157](#) - see page 25.

Type	Capacity	Part No.	Wt lb (kg)
Self-Centering Single	100A	<b>13625</b>	3.2 (1.45)
Self-Centering Tandem	200A	<b>13628</b>	6.0 (0.72)

## 100A J-Head, H-Base Type

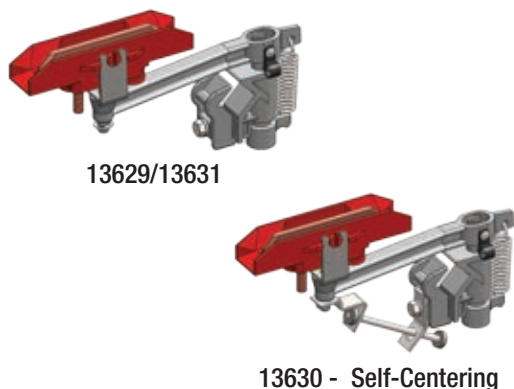

For straight system runs of 600V or less, and curves to a minimum of 48" radius. Assemblies have 21" pigtails (not shown in the illustration). Choose standard bottom entry or lateral-mount versions. The "Self-Centering" version is used with Pick-up Guides - See page 18 - and are for bottom-entry mounting.

Replacement shoe for this collector is Part No. [11157](#) - see page 25.

Type	Part No.	Wt lb (kg)
Single	<b>13629</b>	1.4 (0.65)
Self-Centering Single	<b>13630</b>	1.7 (0.77)
Lateral-Mount Single	<b>13631</b>	1.4 (0.65)

# 8 Bar Shoes, Curves, & Slip Rings

## Replacement Collector Shoes

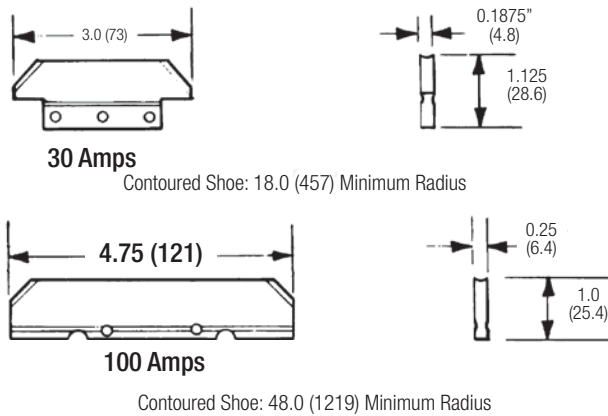

Standard shoe material is copper graphite. The optional cast iron shoe is to be used temporarily to clean the bar. "Insuloy" has self-cleaning properties, but will cause more wear on the bar versus copper graphite.

Cap.	Material	Application	Part No.	Wt. lb (kg)
30A	Copper Graphite	Standard	<b>13136</b>	0.12 (0.05)
30A	Cast Iron	Cleaning shoe	<b>13138</b>	0.12 (0.05)
30A	Insuloy	Self-cleaning	<b>19678</b>	0.12 (0.18)
60A	Copper Graphite	Standard	<b>11154</b>	0.13 (0.06)
100A	Copper Graphite	Standard	<b>11157</b>	0.23 (0.10)
100A	Cast Iron	Cleaning shoe	<b>11159</b>	0.25 (0.11)
100A	Insuloy	Self-cleaning	<b>19347</b>	0.23 (0.10)

## Curved 8 Bar

Factory curved conductors. Refer to page 26 to specify your curve requirements. Contact factory for assistance. Maximum length: 10 feet (3.05 meters).

**Minimum bend radius:** PVC - 18.0" (457 mm); Lexan Medium Heat or Polyester High Heat- 57" (1447 mm)

Conductor Bar	Current Cap.	Part No.		
		PVC Cover	Lexan Cover	Polyester Cover
Galvanized Steel	110A	<b>11003</b>	<b>11022</b>	<b>11041</b>
Stainless Clad Copper Laminate	250A	<b>11007</b>	<b>11026</b>	<b>11045</b>
Copper Steel Laminate	250A	<b>11011</b>	<b>11030</b>	<b>11049</b>
Rolled Copper	350A	<b>11015</b>	<b>11034</b>	<b>11053</b>
Solid Copper	500A	<b>11018</b>	<b>11037</b>	<b>11056</b>



## Slip Rings

Factory manufactured curved segments for slip ring use. Contact factory for assistance.

Conductor Bar	Current Cap.	Ring Radius Range in. (mm)	Pieces	Part No.	
				PVC	Lexan
Galvanized Steel	110A	18-35 (457- 889)	2-180 <sup>0</sup>	<b>23626</b>	n/a
Stainless Clad Copper Laminate	250A	18-35 (457- 889)	2-180 <sup>0</sup>	<b>23627</b>	n/a
Copper Steel Laminate	250A	18-35 (457- 889)	2-180 <sup>0</sup>	<b>23628</b>	n/a
Rolled Copper	350A	18-35 (457- 889)	2-180 <sup>0</sup>	<b>23629</b>	n/a
Galvanized Steel	110A	35-54 (892-1371)	3-120 <sup>0</sup>	<b>23630</b>	n/a
Stainless Clad Copper Laminate	250A	35-54 (892-1371)	3-120 <sup>0</sup>	<b>23631</b>	n/a
Copper Steel Laminate	250A	35-54 (892-1371)	3-120 <sup>0</sup>	<b>23632</b>	n/a
Rolled Copper	350A	35-54 (892-1371)	3-120 <sup>0</sup>	<b>23633</b>	n/a
Solid Copper	500A	35-54 (892-1371)	3-120 <sup>0</sup>	<b>24292</b>	n/a
Galvanized Steel	110A	54-72 (1374-1828)	4-90 <sup>0</sup>	<b>23634</b>	<b>23638</b>
Stainless Clad Copper Laminate	250A	54-72 (1374-1828)	4-90 <sup>0</sup>	<b>23635</b>	<b>23639</b>
Copper Steel Laminate	250A	54-72 (1374-1828)	4-90 <sup>0</sup>	<b>23636</b>	<b>23640</b>
Rolled Copper	350A	54-72 (1374-1828)	4-90 <sup>0</sup>	<b>23637</b>	<b>23641</b>
Solid Copper (500A)	500A	54-72 (1374-1828)	4-90 <sup>0</sup>	<b>24293</b>	<b>24294</b>

# 8 Bar Curves & Slip Rings Specification Data

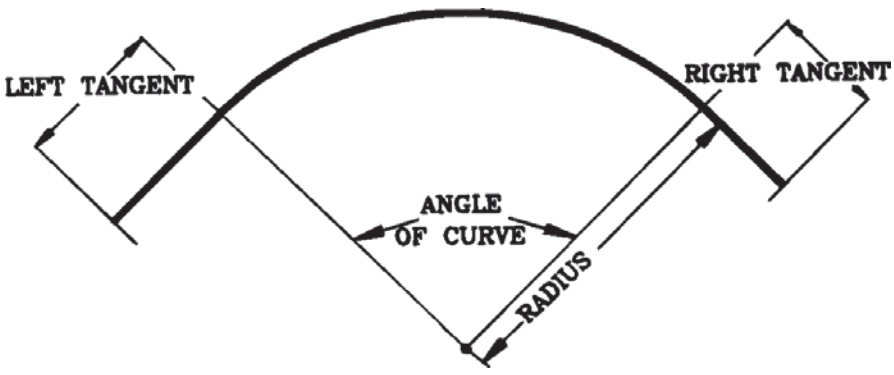
This worksheet is designed to help you choose the correct curved section for your application. Contact factory for assistance.

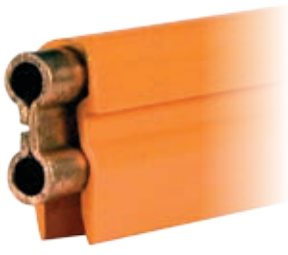
<b>Customer:</b>		
<b>Project No.:</b>	<b>Item No.:</b>	<b>Date:</b>
<b>1. Bar type, Rating (Amps/Volts):</b>		
<b>2. Environment / Ambient Temp:</b>		
<b>3. Fill in</b>		
Angle of curve:		
Left tangent 6" (152 mm) standard:		
Right tangent 6" (152 mm) standard:		
Radius to contact surface: (See page 25 for minimum radii.)		
<b>4. Select style of bar:</b>		
		
* Outside Contact	* Inside Contact	* Bottom Contact
<b>5. For systems with parallel curves, sketch layout below and indicate the radius, angle and tangent for each.</b>		

# 8 Bar Collector Dimensions

## C Base Collectors

Dimensions common to all C-Base Collectors are not repeated.

Type	30 Amp	60 Amp Tandem	100 Amp	200 Amp Tandem
Standard Mount	13128	13082	13613	13626
Self-Centering	13130	13084	13625	13628

Standard Mount, Single - Part No. 13128 Shown

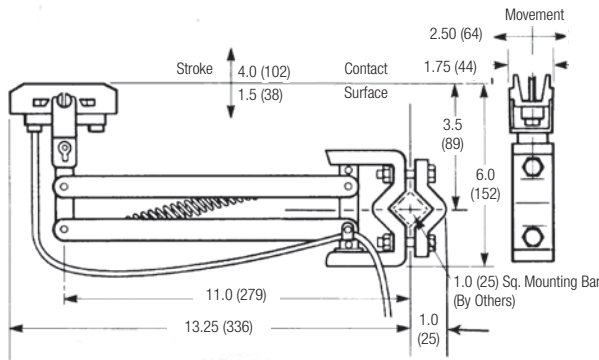

Self-Centering - Part No. 13625 Shown

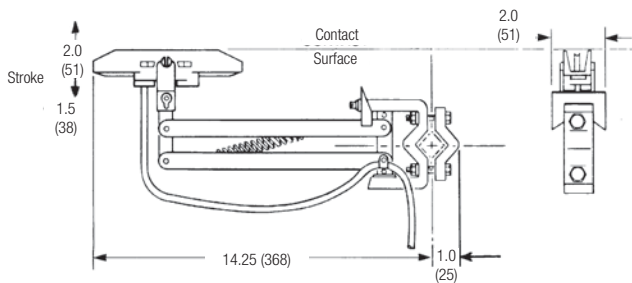

Standard Mount, Tandem - Part No. 13626

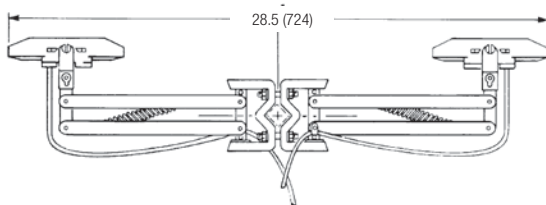

## H Base Collector

Dimensions common to all H-Base Collectors are not repeated.

Type	30 Amp	100 Amp
Standard Mount	13131	13629
Self-Centering	13132	13630

Standard Mount, Single - Part No. 13131 Shown

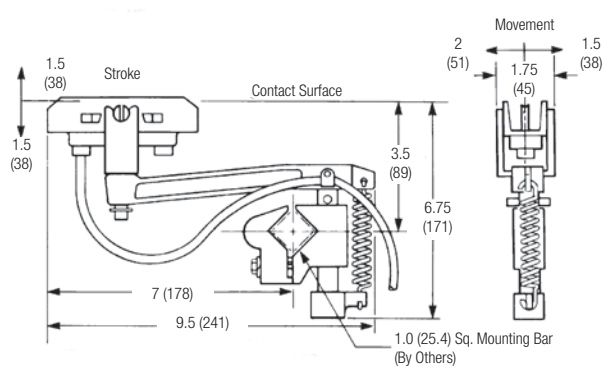

Standard Mount, Single - Part No. 13630 Shown

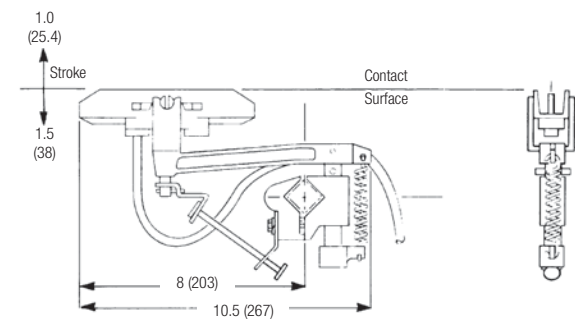

## Collector Mounting

Standard Mount  
(Vertical Entry)

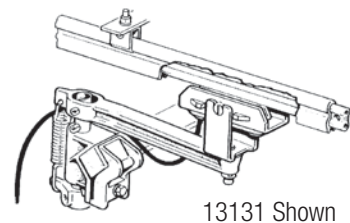

13131 Shown

## Shoe Pressure

30 amp: 3-5 lb  
100 amp 6-9 lb

# 8 Bar Hanger and Anchor Dimensions

Note: Plastic or steel snap-in hangers are not recommended for lateral mounting or curves.

## Plastic Snap-in Hanger Clamps, 250° F

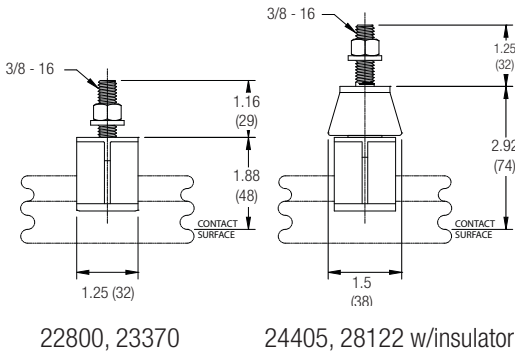

## Spring Steel Snap-in Hanger Clamps, 400° F

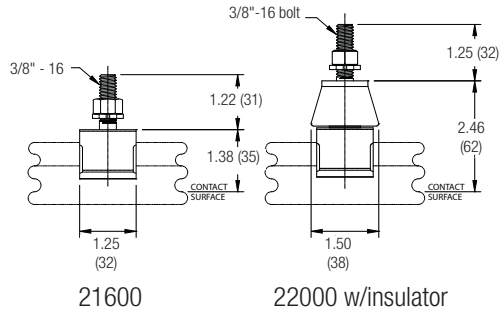

## Cross-Bolt Hanger Clamps

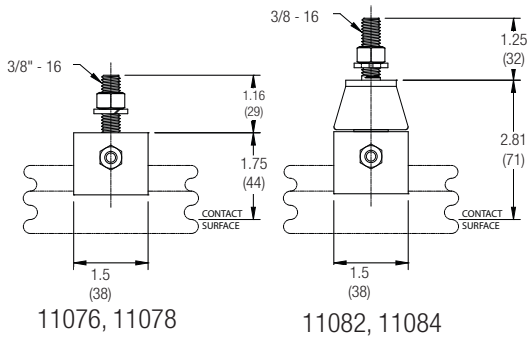

## Anchor Clamp, 400° F

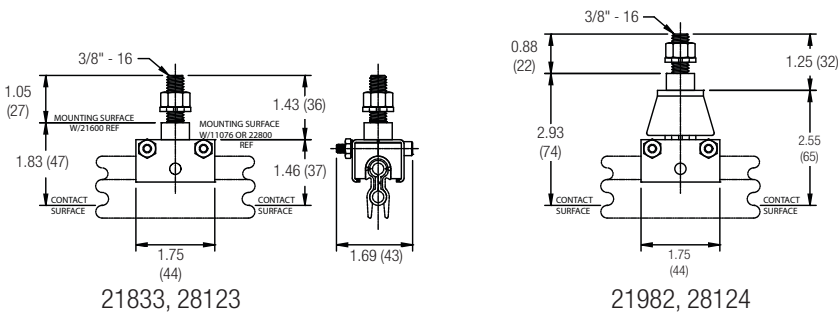

## Insulator, 400° F

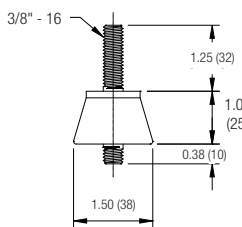

11087 (plated inserts); 16424 (stainless inserts)

## Transfer Cap, 300° F



	Center	Left	Right
40, 110, 250, 350 amp	13161	14118	14119
90 amp only	22070	22395	22396



# 8 Bar Component Dimensions

## Power Feeds

11092, 11093, 27104

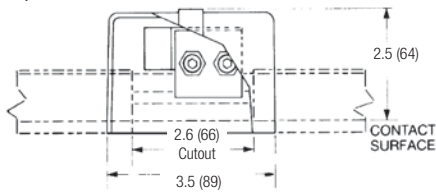

11091, 11122

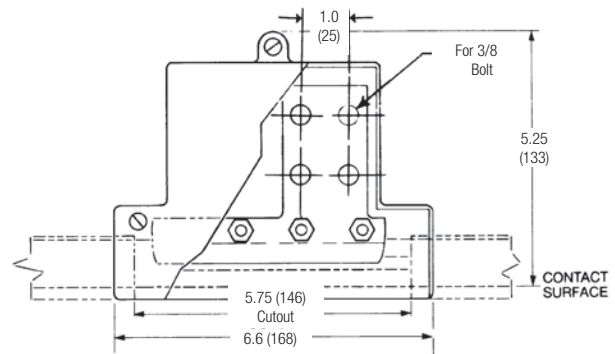
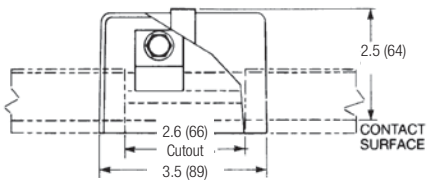

11094, 27106

Part No.	Current Cap. (Amps)	Temp. Rating °F (°C)	Description
11091	90 / 110	160 (71.1)	Steel clamp type. Complete assembly of clamp and PVC case for steel systems only. Single bolt hole 1/4" for 3/0
11122	90 / 110	400 (204.4)	Steel clamp type. Complete assembly of clamp and high-heat case for steel systems only.
11092 / 27104	250	160 (71.1)	Copper clamp type. Complete assembly of clamp and PVC case for systems with feed wires from #8 AWG to 1/0.
11093	250	400 (204.4)	Copper clamp type. Complete assembly of clamp and high heat case for systems with feed wires from #8 AWG to 1/0.
11094 / 27106	500	400 (204.4)	Copper clamp type with stub. Complete assembly of clamp with NEMA standard 4-hole stub and case. Feed wires to 500 MCM.

## Gang Hanger Clamp Bracket

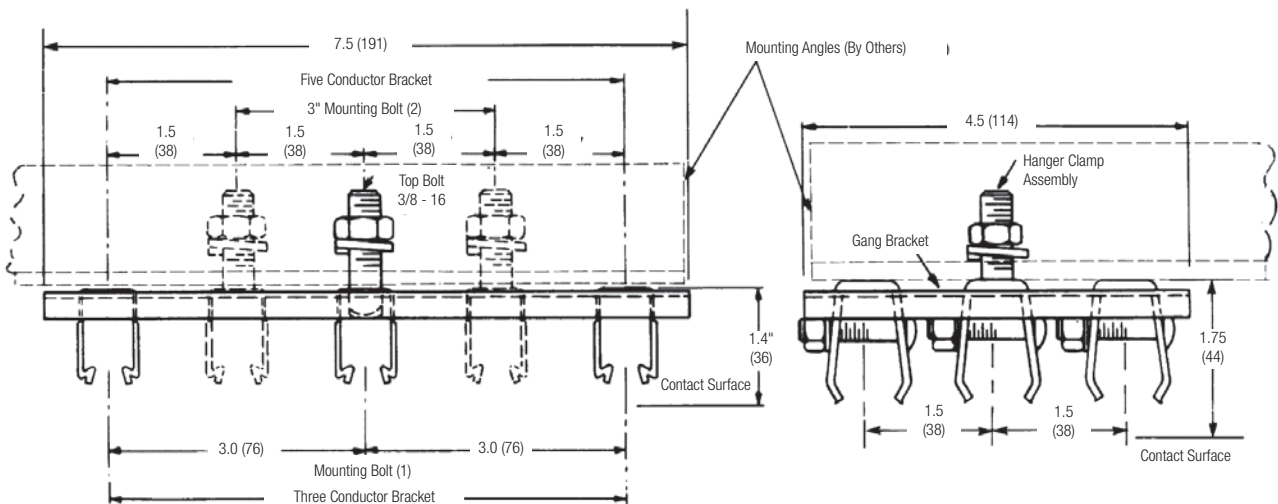

Snap-in Hanger 22646

Cross-Bolt Hanger 22649

# 8 Bar Component Dimensions

## Pick-up Guides

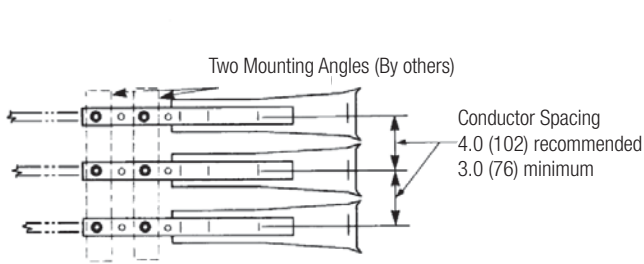

13142 For 'J' head collectors, indoors, 3.0 (76) spacing  
11089 For 'J' head collectors, indoors, 4.0 (102) spacing

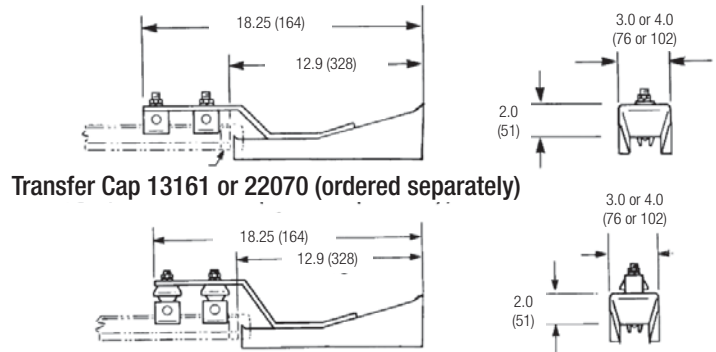

## Collector Bracket, 1.00" (25 mm) square (39617 & 50142)

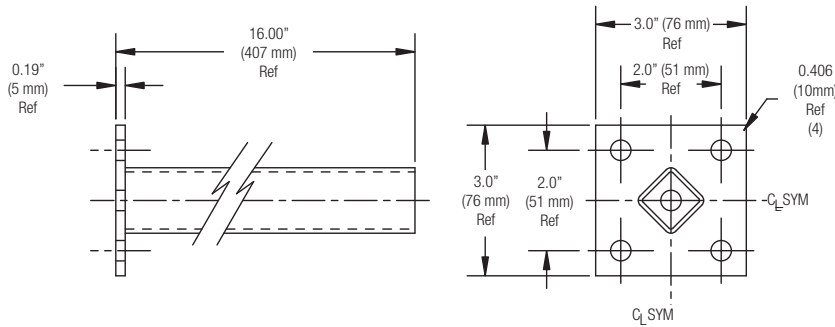

## Crane Bridges and Runways

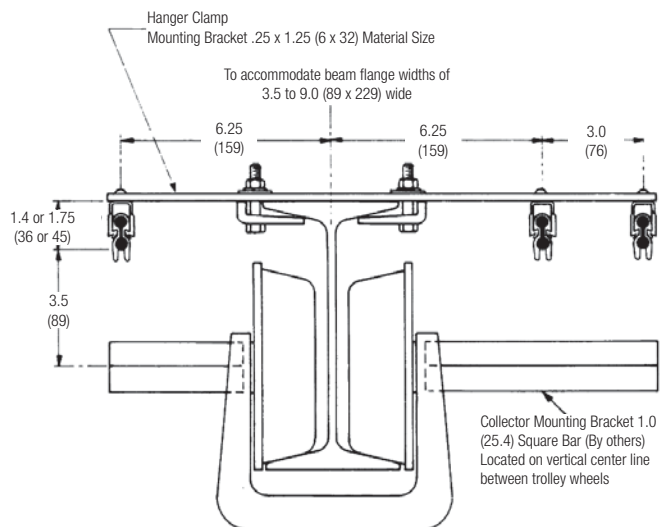
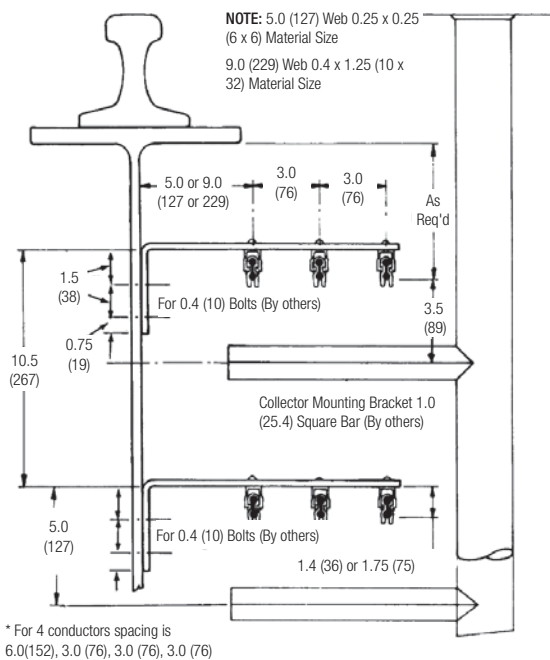

# Insul 8<sup>®</sup> Side Contact Design Features

Conductix-Wampfler Side Contact Conductor Bar is a variation of the 8 Bar system designed for lateral (side) entry of the collector. UL / CSA listed.



## Side Contact is Ideal When:

- There is insufficient room for standard "bottom entry" mounting
- Conductors must be more closely spaced than standard 8 Bar allows

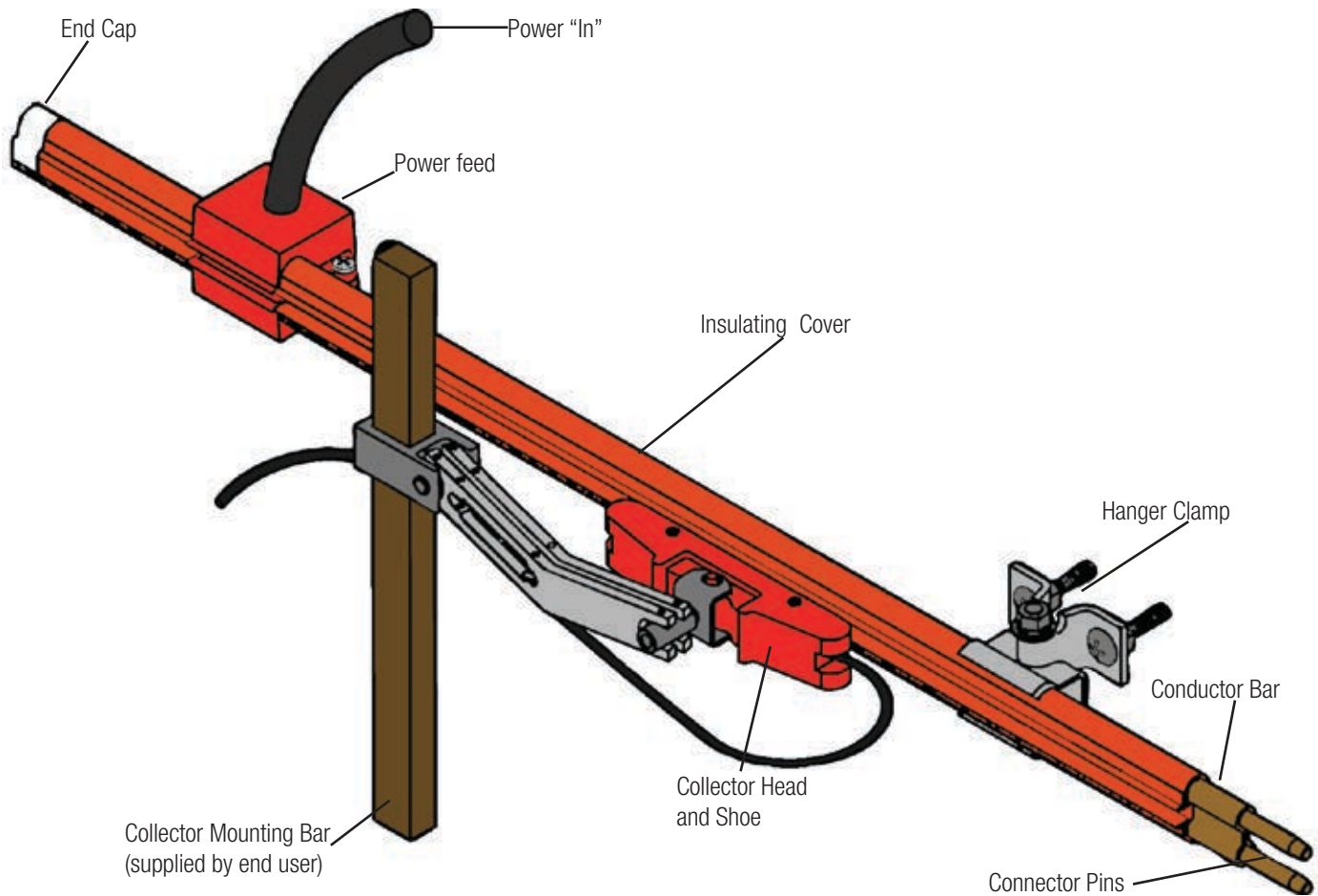

## Component Descriptions

**Conductor Bar:** The supply of incoming power

**Power feed:** Attachment of incoming power

**Collector:** Collects the incoming power and transfers it to the moving machine

**Hangers:** Supports the conductor bar, may also be used as an anchor to direct movement due to expansion and contraction

**End Cover:** Safety protection at the end of conductor system

# Typical Side Contact Mounting Arrangements

Shown below are some typical mounting arrangements for Side Contact. Trolleys on which collectors are mounted must be stabilized, particularly in systems involving discontinuous circuits. One acceptable way is to use guide rollers on the edge of the track flange.

## One Conductor Left and Two Right

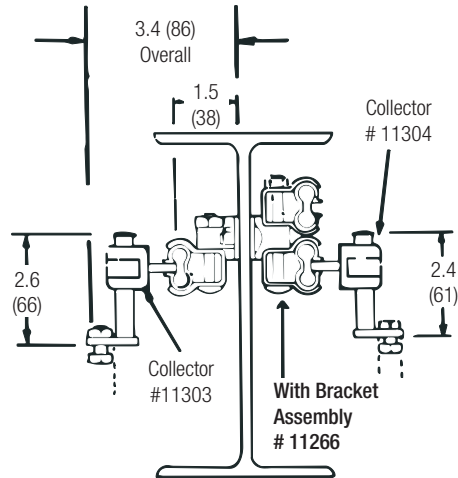

## Two Conductors on the Right

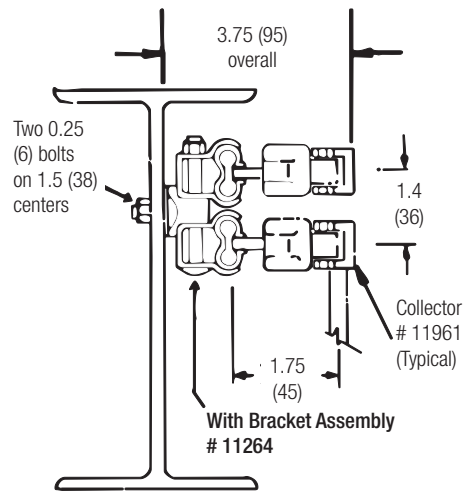

## Two Conductor on the Right, Two on the Left

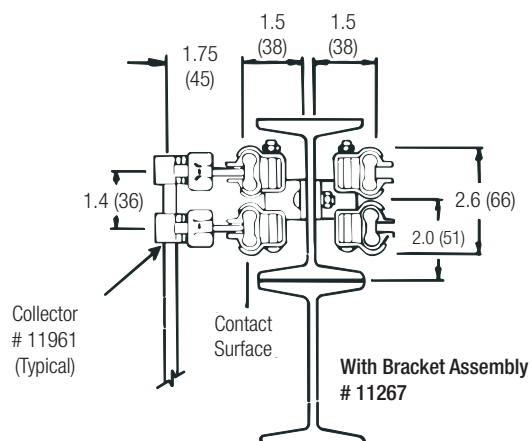

# Side Contact Conductor Bar, Expansions, Power Feeds

Side Contact Conductor Bar comes with cover and connector pins installed. Joint Keepers are required when ordering copper or laminated bar. Bars are available in 40A, 90A, 110A, 250A, and 350A capacities @ 600 volts maximum. Expansion Sections listed below are required every 350 feet (106.7m) for 40A, 90A, and 110A systems or 250 feet (76.2m) for 250A and 350A systems to compensate for thermal expansion. Power Feeds bring outside power to the conductor bar.

Factory installed covers are available in:

- **Rigid PVC:** -10° F to 160° F (- 23.3° C to 71.1° C)
- **Medium Heat:** - 25° F To 250° F (- 31.7° C to 121.1° C)

## Stainless Steel, 40A



Item	Rigid PVC Cover		Medium Heat Cover	
	Part No.	Wt lb (kg)	Part No.	Wt lb (kg)
Conductor Bar, 10 ft (3.05 M)	<b>24273</b>	7.0 ( 3.18)	<b>24298</b>	6.6 (2.99)
Conductor Bar, 5 ft (1.52 M)	<b>24274</b>	3.5 (1.59)	<b>24299</b>	3.3 (1.50)
Expansion Section, 10 ft (3.05 M)	<b>24277</b>	10.0 (4.57)	<b>24302</b>	10.3 (4.67)
Power feed	<b>11289</b>	0.34 (0.15)	<b>11289</b>	0.34 (0.15)
End Cover	<b>11295</b>	0.03 (0.01)	<b>11295</b>	0.03 (0.01)

## Galvanized Steel, 90A



Item	Rigid PVC Cover		Medium Heat Cover	
	Part No.	Wt lb (kg)	Part No.	Wt lb (kg)
Conductor Bar, 10 ft (3.05m)	<b>24275</b>	4.5 (2.04)	<b>24300</b>	4.5 (2.04)
Conductor Bar, 5 ft (1.52m)	<b>24276</b>	3.5 (1.59)	<b>24301</b>	3.3 (1.59)
Expansion Section, 10 ft (3.05)	<b>24278</b>	6.7 (3.04)	<b>24303</b>	6.7 (3.04)
Power feed	<b>11289</b>	0.34 (0.15)	<b>11289</b>	0.34 (0.15)
End Cover	<b>24424</b>	0.03 (0.01)	<b>24424</b>	0.03 (0.01)

## Galvanized Steel, 110A



Item	Rigid PVC Cover		Medium Heat Cover	
	Part No.	Wt lb (kg)	Part No.	Wt lb (kg)
Conductor Bar, 10 ft (3.05m)	<b>11223</b>	7.0 ( 3.18)	<b>11239</b>	6.6 (2.99)
Conductor Bar, 5 ft (1.52m)	<b>11224</b>	3.5 (1.59)	<b>11240</b>	3.3 (1.50)
Expansion Section, 10 ft (3.05)	<b>11255</b>	10.0 (4.57)	<b>11259</b>	10.3 (4.67)
Power feed	<b>11289</b>	0.34 (0.15)	<b>11289</b>	0.34 (0.15)
End Cover	<b>11295</b>	0.03 (0.0)	<b>11295</b>	0.03 (0.01)

# Side Contact Conductor Bar, Expansions, Power Feeds

## Stainless Clad Copper 250A



Item	Rigid PVC Cover		Medium Heat Cover	
	Part No.	Wt lb (kg)	Part No.	Wt lb (kg)
Conductor Bar, 10 ft (3.05m)	<b>11227</b>	7.0 (3.18)	<b>11243</b>	6.6 (2.99)
Conductor Bar, 5 ft (1.52m)	<b>11228</b>	3.5 (1.59)	<b>11244</b>	3.3 (1.50)
Expansion Section, 10 ft (3.05)	<b>11256</b>	11.0 (5.00)	<b>11260</b>	10.3 (4.67)
Power feed	<b>11289</b>	0.34 (0.15)	<b>11289</b>	0.34 (0.15)
End Cover	<b>11295</b>	0.03 (0.01)	<b>11295</b>	0.03 (0.01)

## Copper Steel Laminate 250A



Item	Rigid PVC Cover		Medium Heat Cover	
	Part No.	Wt lb (kg)	Part No.	Wt lb (kg)
Conductor Bar, 10 ft (3.05m)	<b>11231</b>	7.0 (3.18)	<b>11247</b>	6.6 (2.99)
Conductor Bar, 5 ft (1.52m)	<b>11232</b>	3.5 (1.59)	<b>11248</b>	3.3 (1.50)
Expansion Section, 10 ft (3.05)	<b>11257</b>	11.0 (4.99)	<b>11261</b>	10.3 (4.67)
Power feed	<b>11289</b>	0.34 (0.15)	<b>11289</b>	0.34 (0.15)
End Cover	<b>11295</b>	0.03 (0.01)	<b>11295</b>	0.03 (0.01)

## Electrolytic Copper 350A



Item	Rigid PVC Cover		Medium Heat Cover	
	Part No.	Wt lb (kg)	Part No.	Wt lb (kg)
Conductor Bar, 10 ft (3.05m)	<b>11235</b>	7.0 (3.175)	<b>11251</b>	6.6 (2.994)
Conductor Bar, 5 ft (1.52m)	<b>11236</b>	3.5 (1.588)	<b>11252</b>	3.3 (1.497)
Expansion Section, 10 ft (3.05)	<b>11258</b>	11.0 (4.990)	<b>11262</b>	10.3 (4.672)
Power feed	<b>11289</b>	0.4 (0.122)	<b>11289</b>	0.4 (0.122)
End Cover	<b>11295</b>	0.03 (0.014)	<b>11295</b>	0.03 (0.014)

## Expansion Section

Expansion Sections compensate for the thermal expansion that occurs from a combination of ambient heat and electrical heat. Power feeds and flexible jumpers are factory installed to meet electrical and mechanical requirements of each system. Part numbers are located in the conductor tables - See pages 33-34.

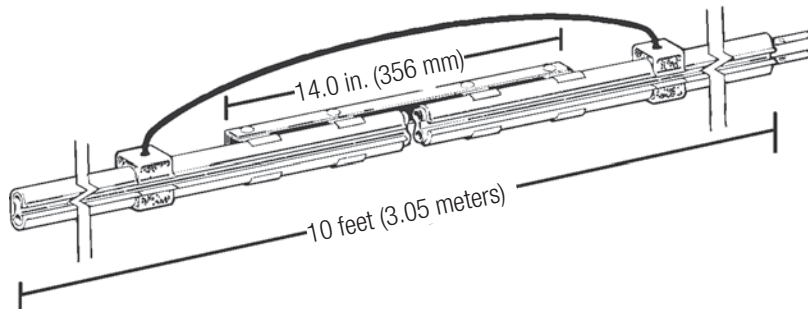



# Side Contact Connectors and Covers

## Connector Pins



Used to join the conductor bar together.

Description	Part No.	Wt lb (kg)
Galvanized steel for 110A	<b>11120</b>	0.8 (0.36)
Copper for 250 and 350A	<b>11121</b>	0.8 (0.36)
Galvanized steel for 90A	<b>21914</b>	0.8 (0.36)
Stainless steel for 40A	<b>24196</b>	0.8 (0.36)

## Insulating Cover



Replacement Part in the event original supplied cover becomes damaged or cracked.

Available in PVC or Lexan cover. The cover is designed for indoor use.

Description	Part No.	Length ft (m)	Wt lb (kg)
Rigid PVC to 160° F	<b>34579</b>	10.0 (3.05)	1.5 (6.80)
Medium Heat to 250° F	<b>11294</b>	10.0 (3.05)	1.5 (6.80)

## End Cover



Used to close the end of the conductors to cover exposed conductor and avoid accidental contact. Also used as a transfer cap for switch applications.

Description	Part No.	Wt lb (kg)
For 40, 110, 250 and 350A	<b>11295</b>	0.03 (0.01)
For 90A	<b>24424</b>	0.03 (0.01)

# Side Contact Power Feed & Pick-up Guide

## Power feed

Fully insulated clamp is easily installed anywhere on the system for feeding power to the conductor bar.



11289 (shown with only half cover)

Description	Part No.	Wt lb (kg)
Complete Assembly, Clamp & Case	<b>11289</b>	0.34 (0.15)
Power feed case with hardware	<b>11290</b>	0.20 (0.09)
Clamp Assembly	<b>11291</b>	0.10 (0.05)

## Pick-up Guides

Used at the end of conductors to guide collectors that completely leave the conductors (Discontinuous Systems) then re-engage.

**Requires use of self-centering collectors, see page 39-40.**

**NOT TO BE USED FOR SWITCH APPLICATIONS**



Description	Part No.	Wt lb (kg)
For all systems (except 90A)	<b>11292</b>	1.25 (0.57)

# Side Contact Hanger Brackets and Clamps

Provides a simple method for installing Side Contact Conductors on conveyors, monorails, bridges, crane runways and switches. These supports secure and separate the insulated conductors uniformly with a minimal amount of installation time. Hanger clamps are all stainless steel with 1/4" zinc plated hardware.

Contact Factory if you need a configurations not shown.

## Single Bar, One Side of Beam

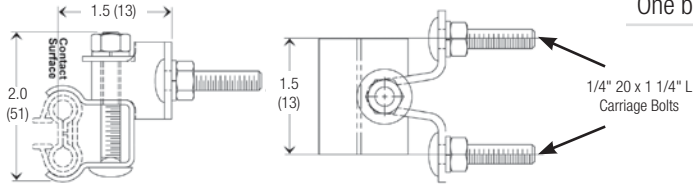

For	Part No.
One bar, one side of beam	11263

## Two Bars, One Side of Beam

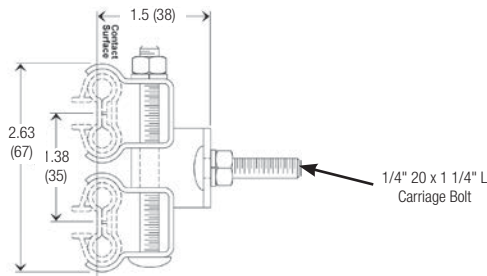

For	Part No.
Two bars, one side of beam	11264

## One Bar, Each Side of Beam

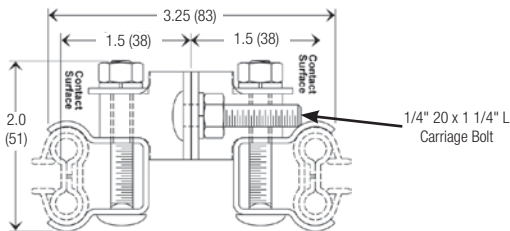

For	Part No.
One bar, each side of beam	11265

## Two Bars One Side of Beam, One on the Other

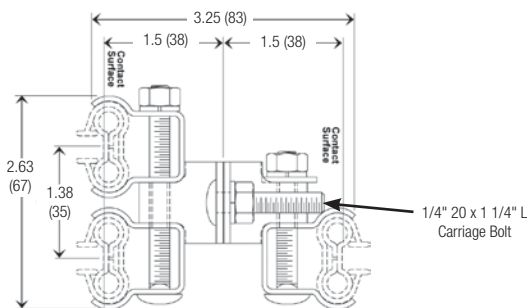

For	Part No.
Two bars one side of beam, one on the other	11266

# Side Contact Hanger Brackets and Clamps

## Two Bars, On Each Side of Beam

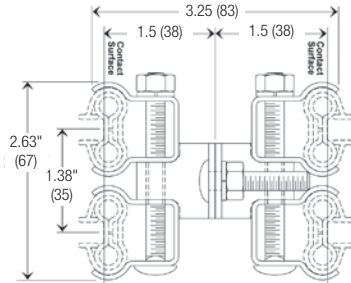

For	Part No.
Two bars, each side of beam	<b>11267</b>

## Three Bars, On One Side of Beam

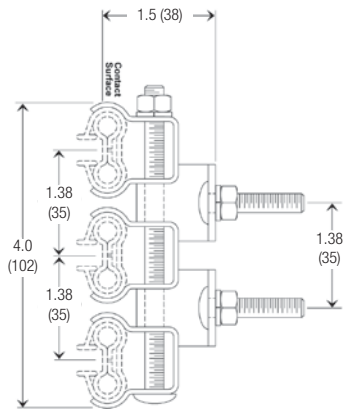

For	Part No.
Three bars on one side of beam	<b>31844</b>

## Single Conductor Hangers

Standard hanger spacing should every 4 feet for straight runs or every 3 feet for curves.



17690



27927

Description	Part No.
Stainless Steel hanger with 1/4" zinc plated hardware	<b>27927</b>
Stainless Steel hanger with 1/4" stainless steel hardware	<b>27926</b>
Stainless Steel hanger with insulator and 1/4" stainless steel hardware	<b>17690</b>

# Side Contact Collectors

Side Contact Collectors are available in numerous configurations to match the application. Note that collectors should not be used as power switching devices. The resultant arcing may cause rapid deterioration of both contact shoes and conductor bars. Ampere capacity of conductor bars, power feeds, jumpers etc., should be greater than or equal to that of the system. Contact factory for systems using tandem mounted collectors and special requirements. For mechanically discontinuous systems, only collectors designated as "self-centering" should be used.

Contact shoe pressure: Between 4 and 6 pounds (1.81 kg to 2.72 kg) for all collector styles.

## M-Head, L-Base Type, 40A



For conveyor, monorail systems, and crane bridges. Operates through curves at a minimum radii of 9.0 (228).

**Standard pigtail length: 15" (381 mm)**

Description	Part No.
Standard Collector, for continuous systems	<b>11961</b>
Self Centering Collector, for discontinuous systems that are equipped with pickup guide 11292	<b>12295</b>

## M-Head, L-Base Type, 80A

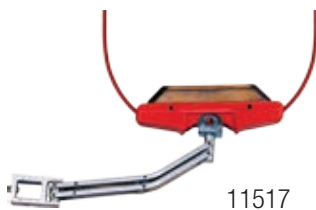

For conveyor, monorail systems, and crane bridges. Operates through curves at a minimum radii of 9.0 (228). Includes an additional pigtail for extra current capacity.

**Standard pigtail length: 15" (381 mm)**

Description	Part No.
Standard Collector, for continuous systems	<b>11517</b>
Self Centering Collector, for discontinuous systems that are equipped with pickup guide 11292	<b>11518</b>

## M-Head, H-Base Type, 40A

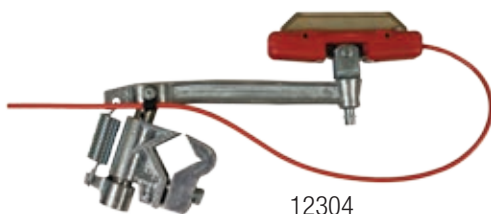

This rugged collector provides a long stroke for continuous systems where clearance is not restricted.

**Standard pigtail length: 15" (381 mm)**

Description	Part No.
Standard Collector, for continuous systems	<b>12304</b>
Same as 12304, except a counter weight is added for lateral mount	<b>12306</b>

# Side Contact Collectors

## M-Head, L-Base Type, Tandem 160A



11519

For systems that require 160A capacity. Operates through curves to minimum radii of 24.0 (610). Has tandem collectors and additional pigtails for the added current capacity.

**Standard pigtail length: 15" (381 mm)**

Description	Part No.
Standard Collector, for continuous systems	<b>11519</b>
Self-centering tandem. For discontinued systems equipped with pickup guide 11292 that require 160A capacity.	<b>15046</b>

## M-Head, L-Base Type, Tandem 80A



11955

Continuous systems that require 80A capacity. Operates through curves to minimum radii of 24.0 (610). Has tandem collectors.

**Standard pigtail length: 15" (381 mm)**

Description	Part No.
Standard Collector	<b>11955</b>
Self-centering tandem. For discontinued systems equipped with pickup guide 11292 that require 80A capacity.	<b>11954</b>

## Side Contact Collector Parts

Description	Part No.
Case only, for M-Head, H-Base Collectors	<b>11307</b>
Case only, for M-Head, L-Base collectors	<b>11300</b>
Contact shoe (copper graphite) for all M-Head collectors	<b>14104</b>
Head assembly for M-Head, H-Base collectors	<b>12296</b>
Head assembly for M-Head, L-Base collectors	<b>11930</b>



# Side Contact Collector Parts and Dimensions

## M-Head, L-Base Collectors (11961 shown)

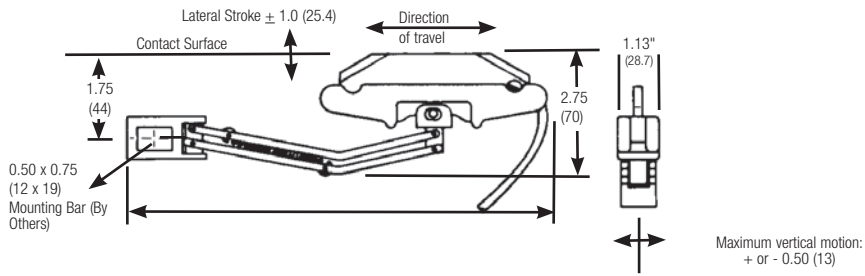

## M-Head, L-Base Collectors, Tandem (11955 shown)

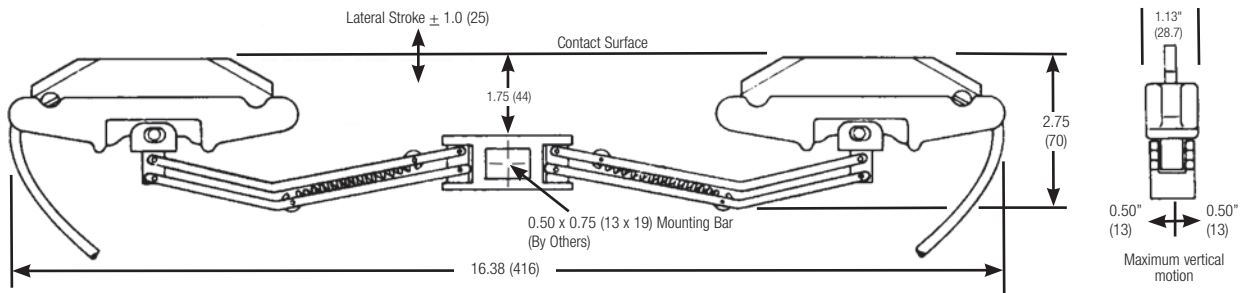

## M-Head, H-Base Collectors (12304 shown)

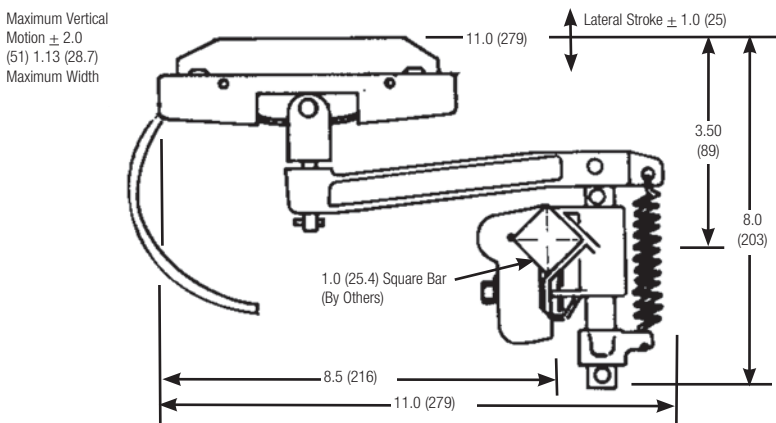

# Side Contact Slip Rings & Curves

## Curves

Side Contact can be set up to handle curves, horizontally or vertically, with standard 6.0 (152) tangents on each end. The systems are specially designed for curves, switches, interlocks, gaps, and continuous control circuits. They are readily adaptable to most operating conditions. Both conductor bar and insulated cover are sufficiently flexible to permit bending to any desired radius up to the noted minimums. Hanger spacing is every 3 feet (0.91 meters) on curves. Maximum bar length is 10 feet (3.05 meters). Information required for curves are:

- Radius for each conductor bar
- Angle
- Inside or outside contact
- Tangents if other than 6" standard.

Conductor Type	Cover	Current Cap. (Amps)	Min. Radius	Part No.
Galvanized Steel	PVC (standard heat)	110	9.0 (229)	<b>11226</b>
Stainless Clad Copper Laminate	PVC (standard heat)	250	9.0 (229)	<b>11230</b>
Copper Steel Laminate	PVC (standard heat)	250	9.0 (229)	<b>11234</b>
Rolled Copper	PVC (standard heat)	350	9.0 (229)	<b>11238</b>
Galvanized Steel	Lexan (medium heat)	110	57.0 (1448)	<b>11242</b>
Stainless Clad Copper Laminate	Lexan (medium heat)	250	57.0 (1448)	<b>11246</b>
Copper Steel Laminate	Lexan (medium heat)	250	57.0 (1448)	<b>11250</b>
Rolled Copper	Lexan (medium heat)	350	57.0 (1448)	<b>11254</b>

## Slip Rings, PVC Standard Heat Covers

Conductor Type	Current Cap. (Amps)	Radius Range - in. (mm)	Pieces	Part No.
Galvanized Steel	110	9.0 to 34.0 (229 to 864)	2-180 <sup>0</sup> pieces	<b>23642</b>
Stainless Clad Copper Laminate	250	9.0 to 34.0 (229 to 864)	2-180 <sup>0</sup> pieces	<b>23643</b>
Copper Steel Laminate	250	9.0 to 34.0 (229 to 864)	2-180 <sup>0</sup> pieces	<b>23644</b>
Rolled Copper	350	9.0 to 34.0 (229 to 864)	2-180 <sup>0</sup> pieces	<b>23645</b>
Galvanized Steel	110	34.5 to 51.0 (876 to 1295)	3-120 <sup>0</sup> pieces	<b>23646</b>
Stainless Clad Copper Laminate	250	34.5 to 51.0 (876 to 1295)	3-120 <sup>0</sup> pieces	<b>23647</b>
Copper Steel Laminate	250	34.5 to 51.0 (876 to 1295)	3-120 <sup>0</sup> pieces	<b>23648</b>
Rolled Copper	350	34.5 to 51.0 (876 to 1295)	3-120 <sup>0</sup> pieces	<b>23649</b>
Galvanized Steel	110	51.1 to 69.0 (1298 to 1753)	4-90 <sup>0</sup> pieces	<b>23650</b>
Stainless Clad Copper Laminate	250	51.1 to 69.0 (1298 to 1753)	4-90 <sup>0</sup> pieces	<b>23651</b>
Copper Steel Laminate	250	51.1 to 69.0 (1298 to 1753)	4-90 <sup>0</sup> pieces	<b>23652</b>
Rolled Copper	350	51.1 to 69.0 (1298 to 1753)	4-90 <sup>0</sup> pieces	<b>23653</b>

# Appendix I - Selection of Systems

Carefully review your equipment and application to choose the correct system and reduce the risk of system failures, equipment downtime, and maintenance time and expense. There are eight interrelated factors that should be considered when selecting the correct system.

## Environmental Conditions

- **Freezing Conditions** - Might require a **heater wire** to keep the conductor contact surface free from ice.
- **Water and/or Dust** - Might adversely affect components and might require the use of insulated hangers to better isolate the “live” conductors from ground.
- **Chemicals** – Can adversely affect system components. Acidic or basic fumes may require stainless steel hardware and components. With the Hevi-Bar II system, you may want to consider the optional “**Dura-Coat**” treatment to reduce component corrosion. This is available for 8-bar; contact the Factory for details.
- **Cutting Oils** – May negatively affect polycarbonate components
- **Radiation** - May require the use of non-PVC components and non-galvanized plated components.

## Mounting and Installation

- **Bottom Entry** – Puts the running surface on the bottom side of the conductor, which keeps dust, water, or debris away.
- **Lateral (or side) Entry** – Can be used if space is limited. Lateral mounting is not recommended for dusty, outdoor, or wet conditions. You may be able to stagger the collectors to decrease the space required for the system.
- **Installation** – Collector Arms are designed to accommodate a certain amount of movement or misalignments between the crane/ vehicle and the conductor. However, if misalignments are excessive the collector could disengage from the bar. **Poor collector installation is the single greatest cause of new system problems.** Installation Instructions should be strictly followed to optimize system performance and prevent problems. Manuals are available at [www.conductix.us](http://www.conductix.us).

## Number of Power and Bonding Conductors Required

- **Power Legs** - Each “power leg” requires one run of bar
- **Bonding (Ground) Bar** - Per article 610.61 (National Electrical Code): “The trolley frame and bridge frame shall not be considered as electrically grounded through the bridge and trolley wheels and its respective tracks. A separate bonding conductor shall be provided”. A bonding bar is required for all overhead cranes built after 2004.

## Moving Versus Stationary Applications

- **Moving Machine** - Draws maximum power as it moves. Current-induced heat is dissipated over a wider area of the conductor.
- **Stationary Machine** - Draws maximum power while stationary for extended periods (e.g.: welding stations, testing equipment, or cranes that repeatedly lift in the same location). Current-induced heat is not easily dissipated when collectors are stationary. In these cases, verify that the collectors and conductors are adequate for the application.

## Current and Voltage Requirements

The purchase of a new conductor system affords the opportunity to size the system for additional cranes or larger cranes that may be added in the future. *A small investment now could avoid major investments in the future.*

- **Conductor Bar Rating** – Per NEC Article 610-14, the bar must accommodate 100% of the current of all the largest motors involved in a single movement, plus 50% of the next largest motors. The auxiliary hoist motor must be included if it works in conjunction with the main hoist. The system also must accommodate 100% the current draw of auxiliary equipment such as magnets, lighting, air conditioners, etc. that operate when the largest motors are energized.
- **Multiple Cranes on a Single Runway** – Sum the amperage requirements of each crane, then apply the appropriate “*diversity factor*” (NEC Table 610-14e). All cranes do not pull the maximum load all the time or pull the load at the same time.
- **Two Cranes Working in Tandem** - Do not apply the diversity factor, since both run at the same time. See Specification Data Sheet, Pgs. 6-7 for further “total load” calculation details.

# Appendix I - Selection of Systems

- **Voltage Rating** - 600 volt rated insulators are standard. Higher voltages require insulators designed for that voltage. Conductor separation may also be affected for medium voltage (e.g. 4160 volts) and higher. The conductor system may need to meet the fault force requirements as determined by a qualified engineer.

**Voltage Drop and Power Feed Locations** Voltage drop along a conductor increases as system length increases and as ambient temperature increases.

- **Maximum Voltage Drop** - The CMAA (Crane Manufacturers Association of America) recommends a maximum voltage drop of 3% on runways and 2% on bridges. The voltage drop in volts will vary according to voltage available. For example, a 3% voltage drop on a 480 volt system is 14.40 volts; a 3% voltage drop at 115 volts is 3.45 volts.
- **Center Power Feed** - Is the optimal location for most systems. Longer runs may require multiple power feed locations to compensate for voltage drop and to minimize the total cost of the system.
- **Multiple Power Feeds** - Can reduce total system cost if the savings of a lower capacity bar offsets the cost to install the multiple powerfeed locations.
- **Calculating Voltage Drop** - Use Conductix-Wampfler Quick Quote (see Pg. 5) to automate this calculation, as shown in the examples below. Voltage drop can also be manually calculated – see Appendix II, Pg. 87.

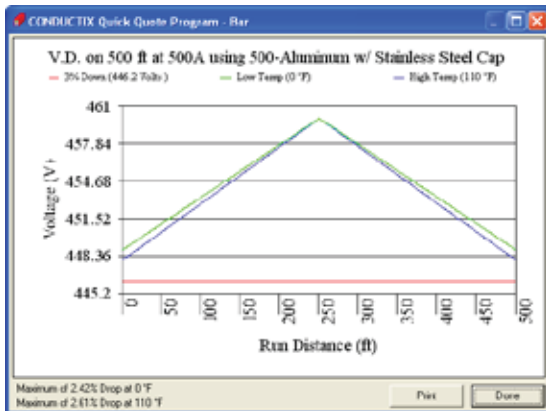

**Figure 1 – Center Feed Example:** Voltage drop along a 500 foot (152.4 meters) long runway with one crane drawing 500 amps at 460 volts on a 500 amp rated bar. The green line shows the voltage drop along the run at 0°F. The blue line shows the voltage drop at 110°F. The red line indicates the 3% maximum voltage drop. The voltage drop increases linearly as you move away from the center feed point.

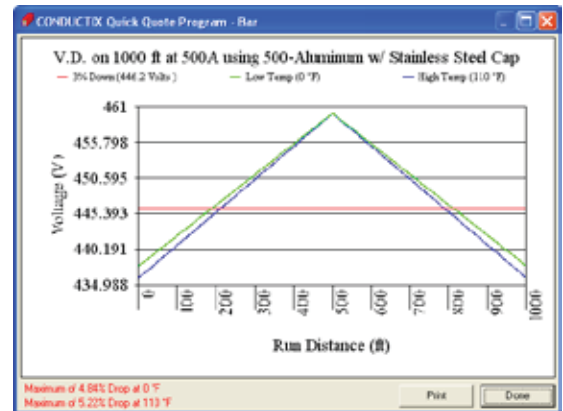

**Figure 2:** Same parameters as Fig. 1, except with a 1000 foot (304.8 meters) system. Note that the voltage drop is now greater than the recommended 3%.

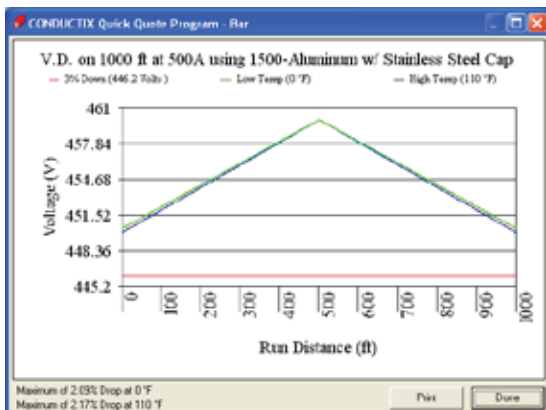

**Figure 3: Center Power Example:** With higher capacity 1500 amp bar to lower the voltage drop below 3%.

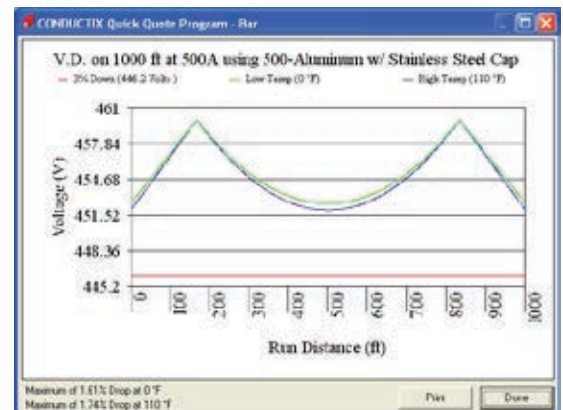

**Figure 4:** Two power feeds optimally located. The voltage drop remains under 3%, without the need to increase conductor capacity. A load positioned between the two feed points is supplied by both power feeds.

# Appendix I - Selection of Systems

## Thermal Expansion/Contraction and Other Effects of Heat

The effects of thermal expansion and contraction become more pronounced as the length of the run increases. The combination of ambient heat plus current-induced heat affects the size of conductor bar needed, the power feed arrangement, and the type of insulating cover required.

- **“Snaking”** – Occurs when the conductors heat up, and due to cumulative hanger friction, start to bow to the side. This can be observed by sighting down the runway. Each bar will bow alternately left and right between hangers, which puts strain on the collectors and hangers. Eventually, the collectors can disengage and damage the system.
- **“Snaking” - Older Systems** - May begin after a year or two in operation. This is because accumulated dirt increases friction between bar and hangers. This possibility should be considered when determining the number of expansions. Precautions taken at the time of installation could avoid costly repairs later.
- **Shorter Systems** - Can be anchored in the center. As the temperature of the conductor rises, the expansion simply pushes the bar outward. The longest system that can be successfully “center-anchored” depends on the friction of the hangers and the rigidity of the conductor.
- **Longer Systems** - Require the installation of one or more **“Expansion Sections”** - i.e. lengths of conductors designed to slide in and out to absorb bar expansion/contraction between anchor points. The slider is bridged by a jumper cable to maintain electrical continuity and acts as the running surface for the collector. Expansion sections effectively break the run into smaller lengths defined by the anchor points. The length of run an expansion section can accommodate is based on expansion/contraction parameters, including temperature range, conductor material, and the length of the slider. The **high end** of the temperature range is the sum of current-induced heat of the bar (at maximum load) plus the highest ambient temperature. The **low end** is the lowest ambient temperature, which may occur during a January system shutdown. Conductor sections need to be anchored properly between each expansion and between the last expansion and the end of the run.
- **Ambient Heat** – All heat sources must be considered and evaluated for their effect on the conductor and cover. Typical heat sources are furnaces, billets, slag, etc. Ambient heat is easy to measure and the effects are consistent with measured values.
- **Radiant Heat** - Can be difficult to measure and its effects hard to anticipate. It will directly affect cover, and the cover might withstand it. However, the effect on metal components might be even more pronounced. For example, metal hangers may heat to such a degree that they will melt the cover. Heat shields provide a good way of minimizing the effects of radiant heat. If heat shields are not practical, higher temperature rated covers might be required.
- **Total Operating Temperature** – The sum of the ambient temperature, radiant heat, and current-induced temperature rise. This is the total heat the conductor and its cover material must withstand. For example, if your machine is working in an ambient temperature of 120°F (49°C), and the current-induced temperature rise of the conductor adds another 50°F, the total 170°F (76.7°C) exceeds the PVC cover rating of 70°C (156°F). The cover will deform or melt, and interfere with collector tracking and/or interrupt power. In this scenario, the cover must be made from a heat-resistant material. Conductix-Wampfler offers “Medium Heat” or “High Heat” covers for most systems – see page 4.

## Conductor Bar Current Rating and Duty Cycle

- **Conductor Electrical Capacity** – A wide variety of capacities are offered, since conductors often power multiple vehicles. Ratings are based on the electrical load the conductor can handle before the operating temperature of the bar exceeds the temperature rating of its cover. The rating assumes a certain ambient temperature (e.g.: 49°C or 120°F) and a specific duty cycle.
- **Duty Cycle** - One manufacturer may rate their conductors for continuous duty; others for intermittent duty based on a given duty cycle. It is important to know which was used to establish the ratings.

# Appendix I - Selection of Systems

- **Continuous Duty** - A conductor is put under a continuous load at some “normal” ambient, usually 30° C. Once the bar temperature has stabilized at the target load rating, the bar temperature cannot exceed the temperature rating of the cover. Most PVC covers can handle approximately 70° C, which is a 40° C rise over 30° C ambient.
- **Intermittent Duty** - Assumes that the current is “on” for a period of time and “off” for a period of time; i.e. one “duty cycle”. The conductor is allowed to cool between “on” phases. A 50% duty cycle is most common – i.e. one minute on and one minute off. Since a crane cannot lift continuously, nor is current flowing at maximum for long periods of time, most operate at a 40% duty cycle or less. So a 50% duty cycle is sufficient. However, cranes that see heavy duty, especially Class D and E cranes (see end of this Appendix), may push the conductor beyond a 50% intermittent duty rating.
- **Collector Electrical Capacity** – A limited selection of collector capacities is available, since collectors only power the crane/vehicle they service. Additional collectors can be used if the crane/vehicle load exceeds the collector rating. Note that the load will not be shared equally among multiple collectors. The collector closest to the power feed will carry a larger load than those farther down the line. So when using multiple sets of collectors, make sure the collector capacities are adequate for this scenario

## CMAA Crane Classifications

Provided for general information only. Refer to CMAA Section 78-6 for full definitions.

**Class A (Standby or Infrequent Service)** Performs precise lifts at slow speed, with long idle period between lifts. Performs lifts at full or near rated capacity. Power houses, public utilities, turbine rooms.

**Class B (Light Service)** Light service requirements at slow speed. Performs 2 to 5 lifts/hour, light to occasional full loads, at 10 ft. average height. Repair shops, light assembly, service buildings, light warehousing.

**Class C (Moderate Service)** Moderate service requirement with loads averaging 50% of capacity. 5 to 10 lifts per hour at 15 foot average lift height. Not more than 50% of lifts at rated capacity. Machine shops, paper mill machine rooms, etc.

**Class D (Heavy Service)** Bucket/magnet duty, where heavy duty production is required. Loads of 50% capacity handled constantly. 10 to 20 lifts per hour averaging 15 ft. lift-height. Not over 65% of the lifts at rated capacity. Heavy machine shops, foundries, fabricating plants, steel warehouses, container yards, lumber mills, etc.

**Class E (Severe Service)** Loads approaching capacity throughout the life of the crane. 20 or more lifts per hour at or near rated capacity. Magnet/bucket cranes for scrap yards, cement mills, lumber mills, fertilizer plants, container handling.

**Class F (Continuous Severe Service)** Handles loads approaching capacity continuously under severe service conditions throughout the life of the crane. Includes custom designed specialty cranes performing work critical to the total production facility. Needs to have the highest reliability and ease of maintenance.

**For system recommendations based on Crane Class, contact Conductix-Wampfler Sales.**



# Appendix II - Voltage Drop Calculations

Proper selection of conductor and covers for Conductix-Wampfler conductor systems is simple, requiring only the ampacity, voltage and ambient conditions.

The method for determining the rating for cranes and hoists is completely outlined in NEC 640-14(e). Further reference to the Code is made where applicable.

- I. For a single crane, simply use the nameplate full load ampere rating of the largest motor or group of motors for any one function plus half the rating of the next largest motor or motor groups.

$$\begin{array}{r} \text{Hoist} = 65A \times 1 = 65.0 \\ \text{Bridge} = 27A \times .5 = 13.5 \\ \hline \text{Total} \quad \underline{78.5A} \end{array}$$

For multiple cranes, use the same method for each crane, add the results and multiply by the demand factor shown in table 610-14(e) NEC Book. Examples with data taken from motor nameplates - all are 460V, 3-phase, 60 Hz.

$$\begin{array}{r} \text{Crane \#1} \\ \text{Hoist} = 65A \times 1 = 65.0 \\ \text{Bridge} = 27A \times .5 = 13.5 \\ \hline \text{Total} \quad \underline{78.5A} \end{array}$$

$$\begin{array}{r} \text{Crane \#2} \\ \text{Hoist} = 52A \times 1 = 52.0 \\ \text{Bridge} = 14A \times .5 = 7.0 \\ \hline \text{Total} \quad \underline{59.0A} \end{array}$$

$$\text{Total of \#1 + \#2} \quad \underline{137.5 \times .195 = 130.0A}$$

- II. When the motor ampere ratings are unknown, a good approximation may be made using the nominal horse power ratings of the motors, converting them to full load amperes per NEC table 430-150; then proceed as above. If the motors are not three-phase, applicable tables 430-137 through 430-149 must be used.

A few examples from the tables are:

## Full-Load Current (Three-Phase Alternating-Current Motors)

HP	230V	460V	575V
10	28	14	11
15	42	21	17
20	54	27	22
25	68	34	27
30	80	40	32
40	104	52	41
50	130	65	52
60	154	77	62
75	192	96	77
100	248	124	99
125	312	156	125
150	360	180	144
200	480	240	192

## Full-Load Current in Amperes, Direct-Current Motors Armature Voltage Rating (Direct-Current)

HP	240V	HP	240V
10	38	60	206
15	55	75	255
20	72		
25	89		
		100	341
30	106	125	425
40	140	150	506
50	173	200	675

## Voltage Drop

Voltage drop is the difference between the voltage at the feed point and the voltage at the extreme end. It is usually expressed as a percentage of the supply voltage and can be calculated as shown below.

Voltage drop increases in direct proportion to the length of the conductors. The CMAA specifications limit total voltage drops to 3% on runways and 2% on bridge conductors. Since power feeds are usually located at the mid-point of a system, the effective length is the distance from power feed to the end of the runway. On longer systems it may be necessary to provide additional feed points.

## Voltage Drop per 100 Feet of Run Per 100A of Current

Conductor	3-Phase 60 Hz	D.C.
Stainless Steel 40A	16.0	18.5
Galvanized Steel 90A	12.1	13.9
Galvanized Steel 110A	9.6	11.1
Stainless Clad Copper 250A	5.7	6.6
Copper Steel Laminate 250A	5.5	6.4
Rolled Copper 350A	5.2	6.0
Solid Copper 500A	5.9	6.8

## 3% at Max Amps and Length from Power feed

Bar	Amps	480V	240V
SS	40	102'	51'
Galv	90	99'	49'
Galv	110	130'	65'
SS / CU	250	287'	144'
CU / Galv	250	287'	144'
Rolled Cu	350	296'	148'
Solid Cu	500	381'	191'

3% of 480V = 14.4  
2% of 240V = 7.2  
2% of 180V = 9.6  
2% of 240V = 4.8



# Appendix III Electrical Formulas & Conversions

## Electrical Formulas

### Ohms Law

$\text{Ohms} = \frac{\text{volts}}{\text{amperes}}$	$\text{Amperes} = \frac{\text{volts}}{\text{ohms}}$	$\text{Volts} = \text{amperes} \times \text{ohms}$
-----------------------------------------------------	-----------------------------------------------------	----------------------------------------------------

### Power

<p><math display="block">\text{Watts} = \text{amperes} \times \text{volts}</math></p> <p><math display="block">\text{Amperes} = \frac{\text{watts}}{\text{volts}}</math> (not 3-Phase)</p> <p><math display="block">\text{HP} = \frac{\text{volts} \times \text{amps} \times \text{efficiency}}{746}</math></p> <p><math display="block">\text{Power Factor} = \frac{\text{watts}}{\text{amperes} \times \text{volts}}</math></p>	<p><b>3-phase</b>  <math display="block">\text{Kilowatts} = \frac{\text{volts} \times \text{amperes} \times \text{power factor} \times 1.732}{1000}</math></p> <p><b>3-phase</b>  <math display="block">\text{Amperes} = \frac{746 \times \text{HP (Horsepower)}}{1.732 \times \text{volts} \times \text{efficiency} \times \text{power factor}}</math></p> <p><b>3-phase</b>  <math display="block">\text{Volt-Amperes} = \text{volts} \times \text{amperes} \times 1.732</math></p> <p><b>Single-phase</b>  <math display="block">\text{Kilowatts} = \frac{\text{volts} \times \text{amperes} \times \text{power factor}}{1000}</math></p> <p><b>Single-phase</b>  <math display="block">\text{Amperes} = \frac{746 \times \text{HP (Horsepower)}}{\text{volts} \times \text{efficiency} \times \text{power factor}}</math></p>
---------------------------------------------------------------------------------------------------------------------------------------------------------------------------------------------------------------------------------------------------------------------------------------------------------------------------------------------------------------------------------------------------------------------------------------	-------------------------------------------------------------------------------------------------------------------------------------------------------------------------------------------------------------------------------------------------------------------------------------------------------------------------------------------------------------------------------------------------------------------------------------------------------------------------------------------------------------------------------------------------------------------------------------------------------------------------------------------------------------------------------------------------------------------------------------------------------------------------------------------------------------------------------------------------------

### Speed

$\text{Synchronous RPM} = \frac{\text{Hertz} \times 120}{\text{poles}}$	$\text{Percent Slip} = \frac{\text{Synchronous RPM} - \text{Full Load RPM}}{\text{Synchronous RPM}} \times 100$
-------------------------------------------------------------------------	-----------------------------------------------------------------------------------------------------------------

### Metric Conversions

To Obtain	Multiply
Millimeters	Inches x 25.4
Inches	Millimeters x 0.0394
Meters	Feet x .3048
Feet	Meters x 3.281
Square Centimeters	Square Inches x 6.45
Square Inches	Square Centimeters x 0.155
Kilograms	Pounds x 0.4536
Pounds	Kilograms x 2.205
Kilograms per Meter	lb/ft (divided by) .6719
Pounds per Foot	kg/m X .6719
Degrees Celsius	(Degrees F-32) x 5/9
Degrees Fahrenheit	(Degrees C x 9/5) + 32

# Appendix IV Terms, Conditions, and Warranty

The technical data and images which appear in this catalog are for informational purposes only. NO WARRANTIES, EXPRESSED OR IMPLIED, INCLUDING WARRANTIES OF MERCHANTABILITY OR FITNESS FOR A PARTICULAR PURPOSE, ARE CREATED BY THE DESCRIPTIONS AND DEPICTIONS OF THE PRODUCTS SHOWN IN THIS CATALOG. Conductix-Wampfler (“seller”) makes no warranty and assumes no liability as to the function of equipment or the operation of systems built according to customer design or of the ability of any of its products to interface, operate or function with any portions of customer systems not provided by Conductix-Wampfler.

Seller agrees to repair or exchange the goods sold hereunder necessitated by reason of defective workmanship, and material discovered and reported to Seller within one year after shipment of such goods to Buyer. Except where the nature of the defect is such that it is appropriate in Seller’s judgement to effect repairs on site, the seller’s obligation hereunder to remedy defects shall be limited to repairing or replacing (at Seller’s option), FOB point of original shipment by Seller, any part returned to Seller at the risk and cost of Buyer. Defective parts replaced by Seller shall become the property of Seller.

Seller shall only be obligated to make such repair or replacement of the goods which have been used by Buyer in service recommended by Seller and altered only as authorized by Seller. Seller is not responsible for defects which arise from improper installation, neglect, or improper use or from normal wear and tear.

Additionally, Seller’s obligation shall be limited by the manufacturer’s warranty (and shall not be further warranted by Seller) for all parts procured from others according to published data, specifications, or performance information not designed by or for Seller.

Seller further agrees to replace, or at Seller’s option to provide a refund of the sales price of any goods that did not conform to applicable specifications or which differ from that agreed to be supplied which non-conformity is discovered and forthwith reported to Seller within thirty (30) days after shipment to Buyer. Seller’s obligation to replace or refund the purchase price for non-conforming goods shall arise once Buyer returns such good FOB point of original shipment by Seller at the risk and cost of Buyer. Goods replaced by Seller shall be come property of Seller.

There is no guarantee or warranty as to anything made or sold by Seller, or any service performed, except as to title and freedom from encumbrances, and except as herein expressly stated and particularly without limiting the foregoing. There is no guarantee or warranty, express or implied, of merchantability or of fitness for any particular purpose or against claim of infringement or the like.

Seller makes no warranty (and assumes no liability) as to function of equipment or operation of systems built to Buyer’s design or of the ability of any goods to interface, operate or function with any portions of Buyer’s system not provided by Seller.

Seller’s liability on any claim; whether in contract (including negligence) or otherwise, for any loss or damage arising out of, connected with, or resulting from the manufacture, sale, delivery, resale, repair, replacement or use of any products or, services shall in no case exceed the price paid for the product or services or any part thereof which give rise to the claim. In no event shall Seller be liable for consequential, special, incidental or other damages, nor shall Seller be liable in respect to personal injury or damage to property on the subject matter hereof unless attributable to gross misconduct of Seller, which shall mean an act of omission by Seller demonstrating reckless disregard of the foreseeable consequences thereof.

Seller is not responsible for incorrect choice of models or where products are used in excess of their rated and recommended capacities and design functions or under abnormal conditions. Seller assumes no liability for loss of time, damage or injuries to property or persons resulting from the use of Seller’s products. Buyer shall hold Seller harmless from all liability, claims, suits and expenses in connection with loss or damage resulting from operation of products or utilization of services, respectively, of Seller and shall defend any suit or action which might arise there from Buyer’s name, provided that Seller shall have the right to elect to defend any such suit or action for the account of Buyer. The foregoing shall be the exclusive remedies of the buyer and all persons and entities claiming through the Buyer.



# Other Conductor Rail Products

Conductor rails made by Conductix-Wampfler in Weil am Rhein, Germany, and stocked in the USA, are an ideal choice for the transmission of digital data and power up to 2000 amps and beyond. Special metal rails are used for the accurate transmission of data. Conductix-Wampfler's innovative electronic Powertrans is an extremely efficient system that permits reliable data transmission even under difficult operation conditions.

Conductix-Wampfler conductor rails are available in any number of poles in any desired length and are designed for ease of installation. The rails feature robust construction suitable for harsh industrial environments. Heavy-duty collector assemblies guarantee reliable transmission without interruption for trouble-free operation.

Current collectors articulate along three axes to compensate for variations in assembly tolerances and inevitable travel variations during operation. This permits uninterrupted transmission of energy and digital data and keeps wear to a minimum. Conductor rails are available for travel speeds up to 33 feet per second.

The experienced engineering and sales people at Conductix-Wampfler are experts in applying conductor rails to all kinds of industrial applications

For more information on these rail designs, please contact Conductix-Wampfler.

All Conductix-Wampfler plants in the United States, Germany, France, and Italy are ISO 9001:2000 certified. Our stringent quality systems assure that you will get the right product every time. See page 51 for a sampling of our other quality products.

In 2007, with the merger of Conductix and Wampfler, the company is now the world leader in the design and manufacture of high performance energy and data transmission products for industrial applications.



## 811 Series

Available from 10 to 100 amps for ASRS, monorails, cranes, and special machines. Straight or curved tracks.

## 812 Series

Available from 25 to 400 amps. Ideal for mid-sized cranes, people movers, amusement rides, and special machines. Stainless steel running surface for straight or curved track.

## 813 Series

Available from 500 to 1250 amps. Works well for heavy cranes, people movers, and special machines. Patented stainless steel running surface for straight or curved tracks.

## 815 Series

Available from 32 to 100 amps. A compact multi-conductor system for electrified overhead monorails and slip rings. Either .47 inch (12mm) or .55 inch (14mm) spacing. Straight or curved tracks.

## 831 Series Multiline

Handles from 10 to 125 amps, in 3, 4, or 5 pole configuration. Great for cranes, automated storage and retrieval systems, and special machines. Straight tracks.

## 842 Series BoxLine

Accommodates from 35 to 140 amps in a continuous conductor strip and enclosed "box track" system. 5 or 7 poles. For smaller cranes, work stations, and other applications requiring an enclosed system.

# Other Products from Conductix-Wampfler

The products described in this catalog represent a few of the products from the broad spectrum of Conductix-Wampfler components and systems for the transfer of energy, data, gases, and fluids. The solutions we deliver for your applications are based on your specific requirements. In many cases, a combination of several different Conductix-Wampfler products are needed to fill the application. You can count on all of Conductix-Wampfler's business units for hands-on engineering support - coupled with the perfect solution to meet your energy management and control needs.



### Motor driven cable reels

Motor driven reels by Conductix-Wampfler are the perfect solution for managing long lengths of heavy cable and hoses in very demanding industrial applications. Monospiral, level wind, and random wind spools.



### Slip ring assemblies

Whenever powered machinery needs to rotate 360°, field proven slip ring assemblies by Conductix-Wampfler can flawlessly transfer energy and data. Here, everything revolves around flexibility and reliability.



### Conductor bar

Whether they are enclosed conductor rails, expandable single-pole bar systems, or high amperage bar for demanding steel mill use up to 6000 amps. Conductix-Wampfler's conductor bar is the proven solution to reliably move people and material.



### Spring driven cable reels

We have 60 years experience and trusted brands such as Insul-8, Wampfler, and IER. We offer small cord reels all the way to large multi-motor units, a wide range of accessories, and hazardous location reels.



### Cable Festoon systems

It's hard to imagine Conductix-Wampfler cable trolleys not being used in virtually every industrial application. They are reliable and robust and available in an enormous variety of sizes and models.



### Push Button Pendants

Our ergonomic pendants are ideally suited for industrial control applications. They are available in a wide range of configurations for overhead cranes and other machinery.



### Radio remote controls

Safe, secure, and reliable radios use the latest in microprocessor technology. Available in several models for overhead crane control and other types of machinery.



### Inductive Power Transfer IPT®

The contact-less system for transferring energy and data. For all tasks that depend on high speeds and absolute resistance to wear.



### Energy guiding chains

The "Jack of all Trades" when it comes to managing energy and data cables and air and fluid hoses. A wide range of energy guiding chains are available for many industrial applications.



### Air hoists and balancers

ENDO Air hoists accurately place delicate loads and continuously vary the speed for precise positioning. They run cool in continuous operations.



### Bumpers

Conductix-Wampfler offers a complete range of bumpers for the auto industry, cranes, and heavy machinery. These include rubber, rubber/metal, and cellular types.



### Spring balancers and retractors

ENDO spring balancers by Conductix-Wampfler are rugged, reliable high-precision positioning devices that reduce operator fatigue and assist with accurate tool placement.

# www.conductix.us

## USA / LATIN AMERICA

10102 F Street  
Omaha, NE 68127

Customer Support

Phone +1-800-521-4888

Fax +1-800-780-8329

Phone +1-402-339-9300

Fax +1-402-339-9627

info.us@conductix.com

latinamerica@conductix.com

## CANADA

18450 J.A. Bombardier  
Mirabel, QC J7J 0H5

Customer Support

Phone +1-800-667-2487

Fax +1-800-442-9817

Phone +1-450-565-9900

Fax +1-450-851-8591

info.ca@conductix.com

## MÉXICO

Calle Treviño 983-C  
Zona Centro  
Apodaca, NL México 66600

Customer Support

Phone (+52 81) 1090 9519

(+52 81) 1090 9025

(+52 81) 1090 9013

Fax (+52 81) 1090 9014

info.mx@conductix.com

## BRAZIL

Rua Luiz Pionti, LT 05, QD. L -  
Vila Progresso  
Itu, São Paulo, Brasil  
CEP: 13.313-534

Customer Support

Phone (+55 11) 4813 7330

Fax (+55 11) 4813 7330

info.br@conductix.com

Contact us for our Global Sales Offices

