

AquaCal AutoPilot Kit Instructions

**Replacing Sensors on
Digitally Controlled Heat Pumps
(Defrost or Water Temperature)**

(For use with Sensor Replacement Kit # STK0021)

SECTION 1 - GENERAL INFORMATION

1.1 Contacting AquaCal AutoPilot

Web	www.AquaCal.com
Phone	(727) 823-5642 8-5 pm, Est, M-F
Fax	(727) 821-7471

If you should need to call AquaCal AutoPilot for questions, service, or parts, please have your model and serial numbers available.

1.2 Failure Codes

The following failure code chart indicates what part may need to be replaced.

CODE	DESCRIPTION
dPC/dSC	Defrost Sensor Shorted – Replace defrost sensor.
dPO/dSO	Defrost Sensor Open – Replace defrost sensor.
Pc	Water Temperature Sensor Shorted – Replace water temperature sensor.
Po	Water Temperature Sensor Open – Replace water temperature sensor.
Fs	<ul style="list-style-type: none">• If “fs” is displayed and the compressor is off with an ambient air temperature at 50°F or above, the defrost sensor will need to be replaced.• If “fs” is still displayed after the defrost sensor has been replaced, then the microprocessor will need to be replaced.

1.3 Kit Contents

QUANTITY	DESCRIPTION
1	Sensor (6105D)
1	¼" x 3" X 4" Insulation Wrap
6	9" wire tie (# 8011)
1	Kit Instructions (LTM0083)

1.4 Tools Required

QUANTITY	DESCRIPTION
1	Phillips-Head Screwdriver Medium-Tip
1	Pair of Diagonal Cutters
1	Nut Driver ¼"

SECTION 2 - INSTALLATION



WARNING - Failure to heed the following may result in injury or death.

- Repairs by unqualified persons may result in hazards to self and others. These instructions are intended for use by qualified individuals, familiar with electrical service industry safety standards and methods.
- Follow all applicable codes and standards.
- Heater contains refrigerant under pressure. Repairs to the refrigerant circuit must not be attempted by untrained and/or unqualified individuals. Service must be performed only by qualified HVAC technicians. Recover refrigerant before opening system.
- Rotating Equipment and Electrical Shock Hazard. Disconnect all electrical power prior to servicing equipment.

2.1 Replacing a Failed Defrost Sensor

- 1) Remove heater's front service panel.
- 2) Remove electrical box enclosure' cover.
- 3) Locate the "FS" connection on the right side of the microprocessor terminal strip. See Figure 1. Disconnect the sensor wires from the terminal strip.
- 4) Follow wire from controller to existing sensor probe. Examine wrappers in sensor area:
 - If one (1) insulation wrap is found at sensor, this indicates the sensor and TXV bulb are mounted together...do not disturb this installation. Rather, cut the sensor wires as close as possible to the sensor, removing the wires, but leaving the failed sensor and wrap in place. Then, using two (2) wire ties, and as close as possible to original sensor location, and on a straight section of suction line, strap new probe snugly to suction tube. See Figure 2 for an example of a correctly attached defrost sensor. Cover new sensor with supplied insulation wrap; secure wrap with two (2) wire ties.
 - If two (2) insulation wrappers are found in the sensor probe area, remove the insulation surrounding the probe and suction line; remove the failed probe and associated wires. Then, using two (2) wire ties, and as close as possible to original sensor location, and on a straight section of suction line, strap new probe snugly to suction tube. See Figure 2 for an example of a correctly attached defrost sensor. Cover new sensor with supplied insulation wrap; secure wrap with two (2) wire ties.
- 5) Cover the replacement sensor wires with the previously-removed spiral wrap (spin the wires into the spiral wrap), and route wires into the electrical enclosure. Plug replacement sensor wires onto "FS" connections. Polarity is unimportant. Use wire ties to bundle sensor wires with other control wiring.
- 6) Reinstall electrical enclosure cover and heater front panel. Restore electrical power and water flow; run test heater to verify correct operation.

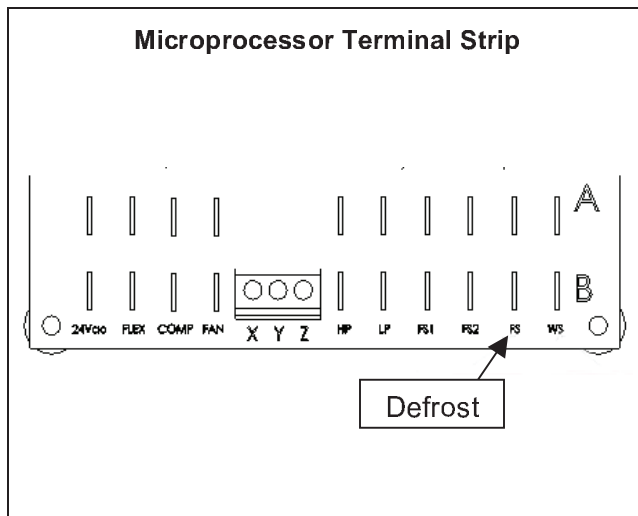

Figure 1

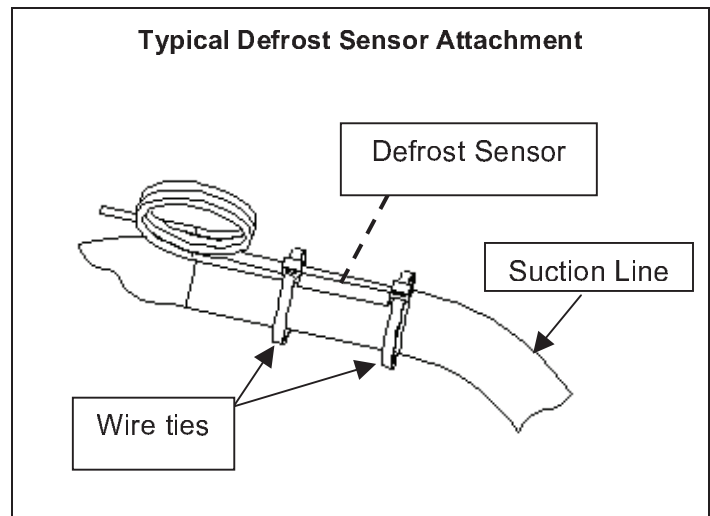

Figure 2

2.2 Replacing a Failed Water Temperature Sensor

- 1) Remove heater front panel screws; remove front panel;
- 2) Remove screws from electrical box enclosure; remove enclosure cover;
- 3) Within electrical enclosure, locate "WS" connections on right side of the microprocessor terminal strip. See Figure 3.
- 4) Locate Existing Sensor Probe: removing the protective spiral wrap, trace the two "WS" wires from the terminal board to the location of the water temperature sensor. Note: water temperature sensor will be found at water thermostat well. See Figure 4 and Figure 5 for possible water sensor locations.
- 5) Remove wire ties holding faulty sensor in place, and remove faulty sensor from thermostat well. Well may be covered with a rubber cap, if so, remove cap to access failed sensor. Remove remaining sensor wiring from heater.

- 6) Install new sensor fully into thermostat well, and secure (in same fashion as removed sensor) with a wire tie;
- 7) Cover the sensor wires with the previously-removed spiral wrap (spin the wires into the spiral wrap), and route wires into the electrical enclosure. Install new sensor wires to "WS" connections; polarity is unimportant. Use wire ties to bundle sensor wires with other control wiring;
- 8) Reinstall electrical enclosure cover and heater front panel; restore electrical power and water flow; run test heater to verify correct operation.

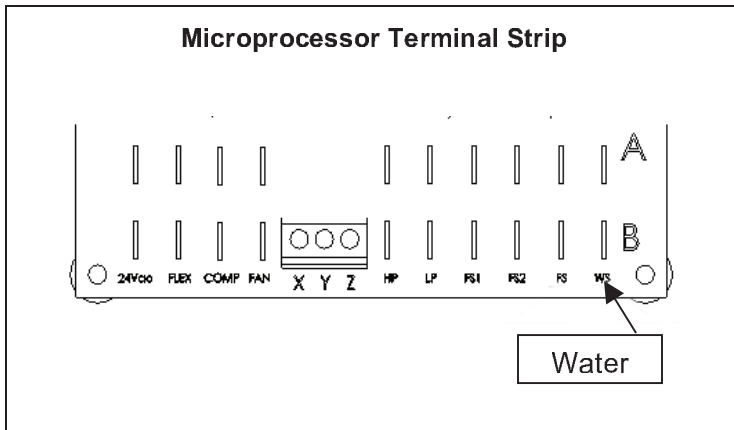

Figure 3

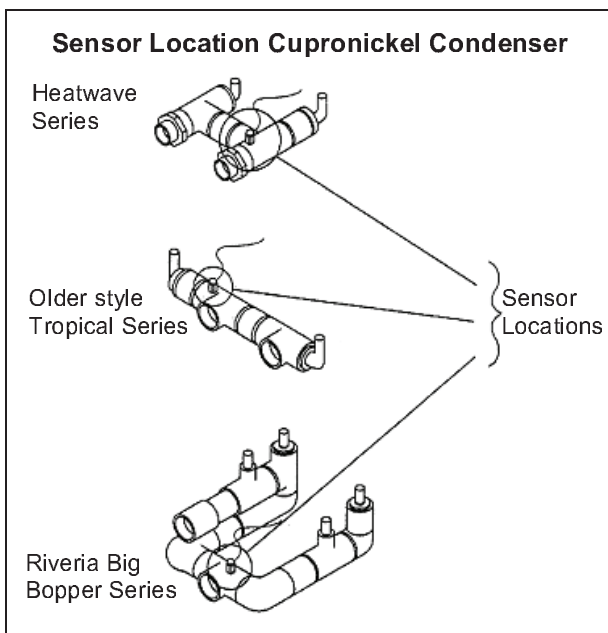

Figure 4

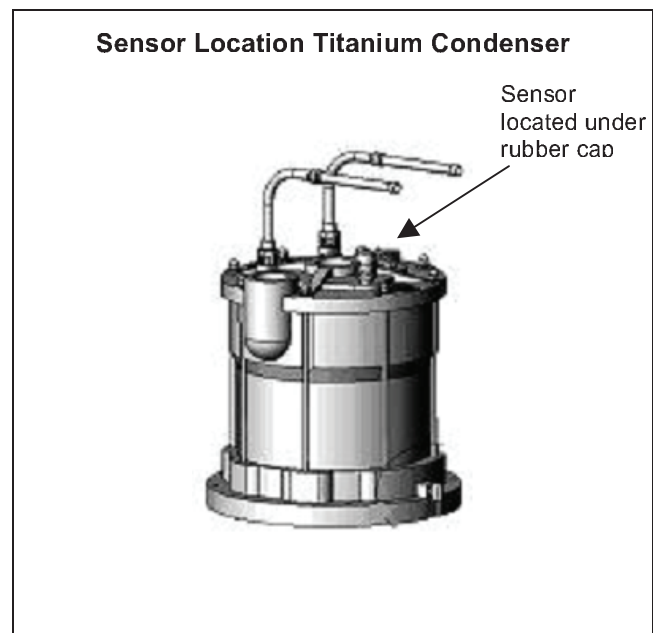

Figure 5

2.3 Alternate Water Sensor Location

If water temperature sensor is affected by the airflow, then it may be beneficial to move or replace the sensor from the titanium heat exchanger and locate it somewhat out of the airflow. We recommend part number ECP0137. The sensor is a fully enclosed sensor and 1/8" NPT thermowell all in one. It is possible to move the 1/4" NPT thermowell in the heat exchanger and relocate this sensor to the inlet piping. We recommend drilling and tapping to a fitting as opposed to a pipe.